

Lixel K2 Handheld Scanner

User Manual(V1.0)

April.2026

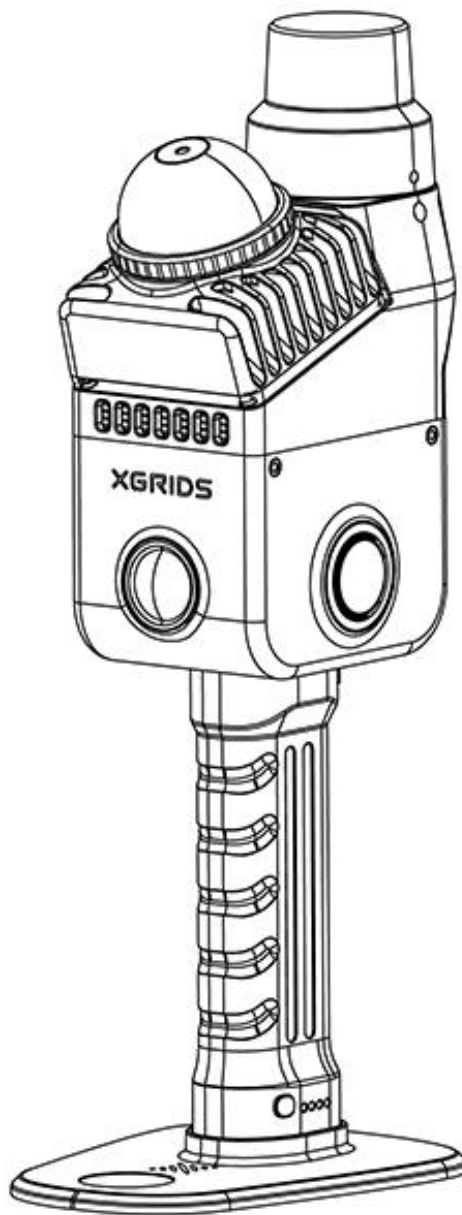

Contents

1 Product Overview	1
2 Basic operation	1
2.1 Battery installation	1
2.2 Base mounting	1
2.3 Battery charging	2
2.4 Function key operation	3
2.5 Indicator light description	4
2.6 Data Transfer Instructions	4
2.7 Basic usage specifications	5
3 Device activation and connection	5
3.1 LixelGO Introduction	5
3.2 Recommended installation environment	6
3.3 Device activation	7
4 Scanning workflow	21
4.1 Connect the device	21
4.2 Scan Mode Settings	23
4.3 Start scanning	25
4.4 Rendering mode	27
4.5 Scan Assist System	28
4.6 Stop scanning	30
4.7 View Model	31

4.8 Downloading scan data	34
4.9 Data project file structure	35
5 Acquire point cloud data with absolute coordinate	37
5.1 Through existing Ground Control Points (GCP)	37
5.2 Through the RTK module	44
6 Map Fusion	51
6.1 Field work: scanning	51
6.2 In-house: data processing	52
7 Route planning suggestions for typical scenes	52
7.1 Principles of the overall scanning route	52
7.2 Outdoor scenes	52
7.3 Indoor scenes	53
8 Precautions	56
8.1 Startup (Instrument Initializing)	56
8.2 General notes	57
8.3 Ground Control Mode	57
8.4 RTK mode	58
8.5 Colorization mode	58
8.6 Accuracy Check	59

1 Product Overview

The Lixel K2 is XGRIDS' lightweight spatial scanner built for real-world conditions — balancing capture efficiency, ease of use, and deliverable quality. From engineering measurement, heritage preservation, to stockpile volumetrics, K2 is the reliable choice for 3D spatial data capture, the gold standard in lightweight spatial scanning.

2 Basic operation

2.1 Battery installation

1. Press the battery buckle
2. Insert the battery into the bottom of the device and ensure it is inserted tightly.
3. Loosen the buckle and confirm that the battery is locked.

Note: Failure to lock the battery may cause the device to slip.

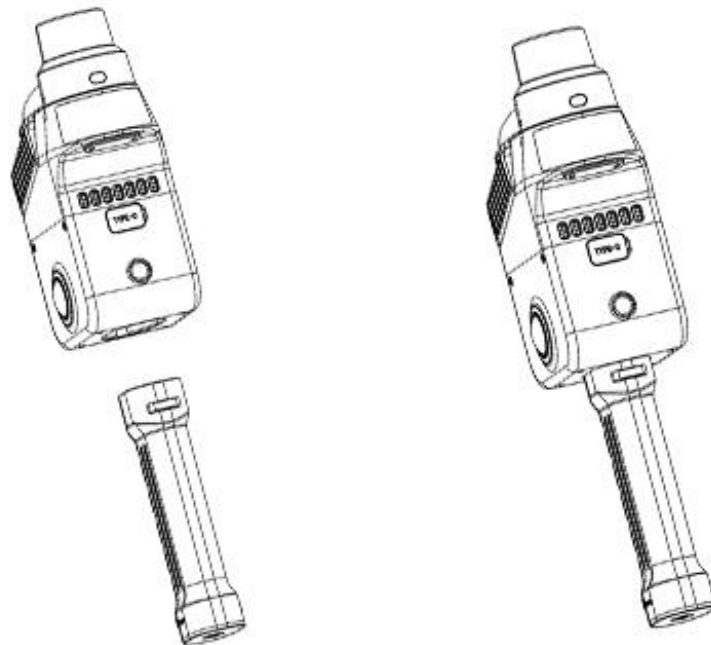

2.2 Base mounting

The battery handle has a threaded hole at the bottom, clip the device into the base, lock

the bottom bolt, and place the device in a flat position.

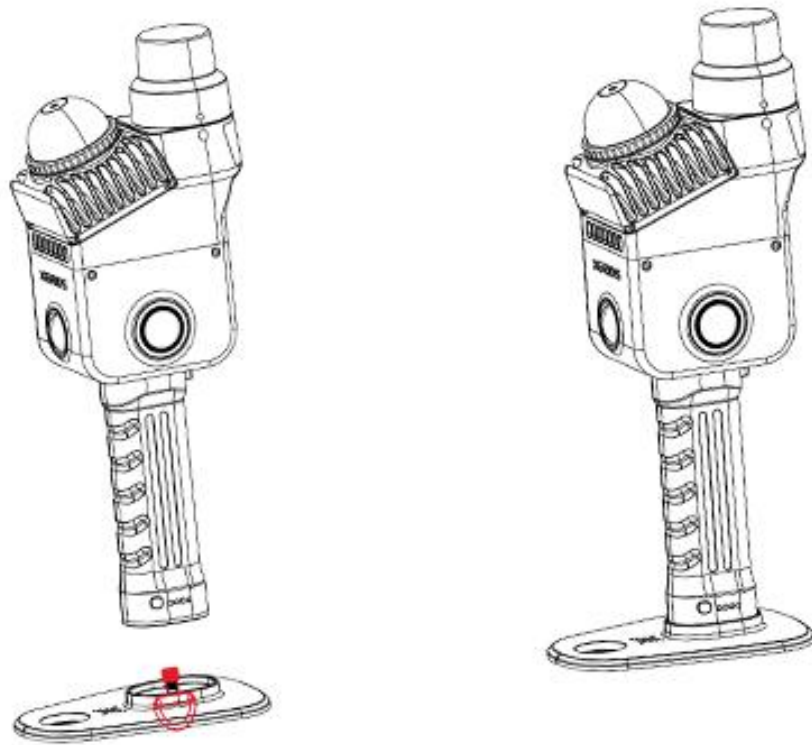



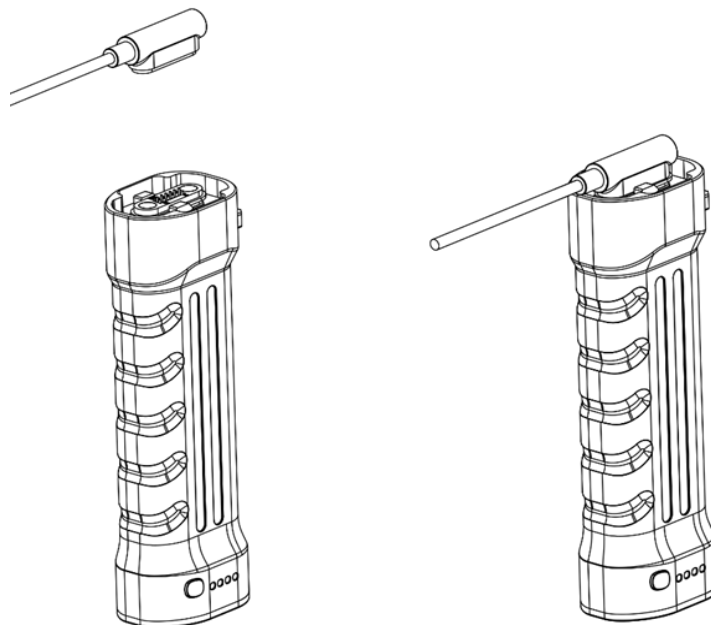

2.3 Battery charging

Use the provided charging cable, connect the charging adapter to the battery, once the indicator light starts flashing, the battery is charging.



Battery full charge time: about 2 hours. During the charging process, the indicator light indicates the current battery level. Please refer to the table below for details.

Flashing Pattern	Battery Level
	0-24%
	25%-49%
	50%-74%
	75%-99%

2.4 Function key operation

Function	Button Operation	Device Status
Power On	Press and hold for 4 seconds	The indicator light will change from slow flashing blue to solid green, indicating the device has entered standby mode.
Power Off	Press and hold for 4 seconds	While in standby mode, long press for 4 seconds. The indicator light will change from solid green to flashing white, indicating the system is saving data. The device powers off once the indicator turns off.
Start Scanning	In standby mode, double-click the button.	The indicator light will switch from solid green to fast-flashing green, then slow-flashing green. The LiDAR will begin to rotate, indicating that scanning has successfully started, and the device has entered scanning mode.
Stop Scanning	In scanning mode, double-click the button.	The indicator light will change from slow-flashing green to fast-flashing green, then solid green. The LiDAR will stop rotating, indicating that scanning has successfully stopped, and the device has returned to standby mode.
Control Point Collection	In scanning mode, single-click the button.	The indicator light will stay on for about 1 second, then return to slow-flashing green. This indicates successful control point recording.
Switch to	In standby	After a single click, the indicator light will turn white and

USB Mode	mode, single-click + indicator light turns white + single-click	remain for up to 3 seconds. During this white light period, single-click the button again to switch to USB mode. If no further action is taken within 3 seconds, the device will remain in its original mode.
----------	-----------------------------------------------------------------	---------------------------------------------------------------------------------------------------------------------------------------------------------------------------------------------------------------

2.5 Indicator light description

Indicator Light Status	Meaning
No light	Device not started
Slow-flashing green light	Scanning mode
Solid green light	Standby mode
Solid blue light	USB mode
Solid yellow light	Device not activated
Solid red light	System error
Slow-flashing blue light (~30s)	Powering on
Solid white light	Switching between standby and USB mode
Fast-flashing green light	Scan starting/stopping
Light alternates between red and green	Upgrading

2.6 Data Transfer Instructions

To transfer data, connect the device to a computer using the provided USB 3.1 cable while the device is in standby mode. Use the app or the power button to switch to USB mode. Once the device is recognized, you can proceed with data copying.

Notes:

The USB mode will automatically disable after a device restart.

If you want to continue scanning after enabling USB mode without powering off or disconnecting the device, you must manually exit USB mode.

Using other USB cables may result in slower transfer speeds or other issues.

On the K2, the USB-C port is orientation-sensitive. If the device is not recognized, flip the cable end 180° and try again.

2.7 Basic usage specifications

1. The Lixel K2 handheld scanner is a kind of precision surveying and mapping equipment. Falling or being hit by external forces may damage the equipment, leading to abnormal work or bad accuracy, or even complete damage to the equipment.
2. When using a tripod, make sure to tighten the tripod and the device cartridge battery to prevent the device from falling.
3. The protection level of the Lixel K2 scanner is IP54 . Please pay attention to the environment when using it and do not use it in an environment exceeding this protection level. It is recommended to use a soft dry cloth or a self-cleaning cloth to clean the equipment. Please keep the LiDAR module and lens parts clean and do not touch them directly with your hands.
4. Do not cover or touch the heat dissipation part of the equipment during use. When the device temperature is too high during use, it may automatically shut down.

3 Device activation and connection

3.1 LixelGO Introduction

LixelGO is a mobile app that comes with the Lixel L and K series scanner. It can be connected and synchronized through WiFi and 5G/4G real-time transmission services, switch between true color and elevation preview modes quickly, support viewing and managing projects, and achieve management of digital 3D space assets in cloud. Scan the code to install the latest version of the app.



IOS version

Go to the App Store and search LixelGO to download and install the latest version of the app.

3.2 Recommended installation environment

Recommended:

Module	Specs
CPU	Recommended Snapdragon series, preferably Snapdragon 8 or above
Random Access Memory	Minimum 8GB
Display chip	It is best to have an independent display chip
Other	it needs to support Bluetooth and Hotspot function; larger storage memory preferred; and longer battery life preferred.

Recommended :

Brand	Product	Processor CPU	Random Access Memory	Graphics card GPU
VIVO	IQOO NEO 6	The first generation Snapdragon 8 + mobile platform	12GB	Adreno 730
Redmi	Redmi K50 E-sports Edition	Qualcomm Snapdragon 8 Gen 1	8GB	Adreno 730

Huawei	Huawei P50E	Snapdragon 778G	8GB	Adreno 642L
OPPO	OPPO K10	Dimensity 8000-MAX Mobile Platform	8GB	Mali-G510 MC6

3.3 Device activation

1. Register and log in to LixelGO

After installing LixelGO, open the app and click Use now to enter the login/registration interface. New users should choose to register by email or mobile phone number. Registered users can log in by account and password or mobile phone verification sms.

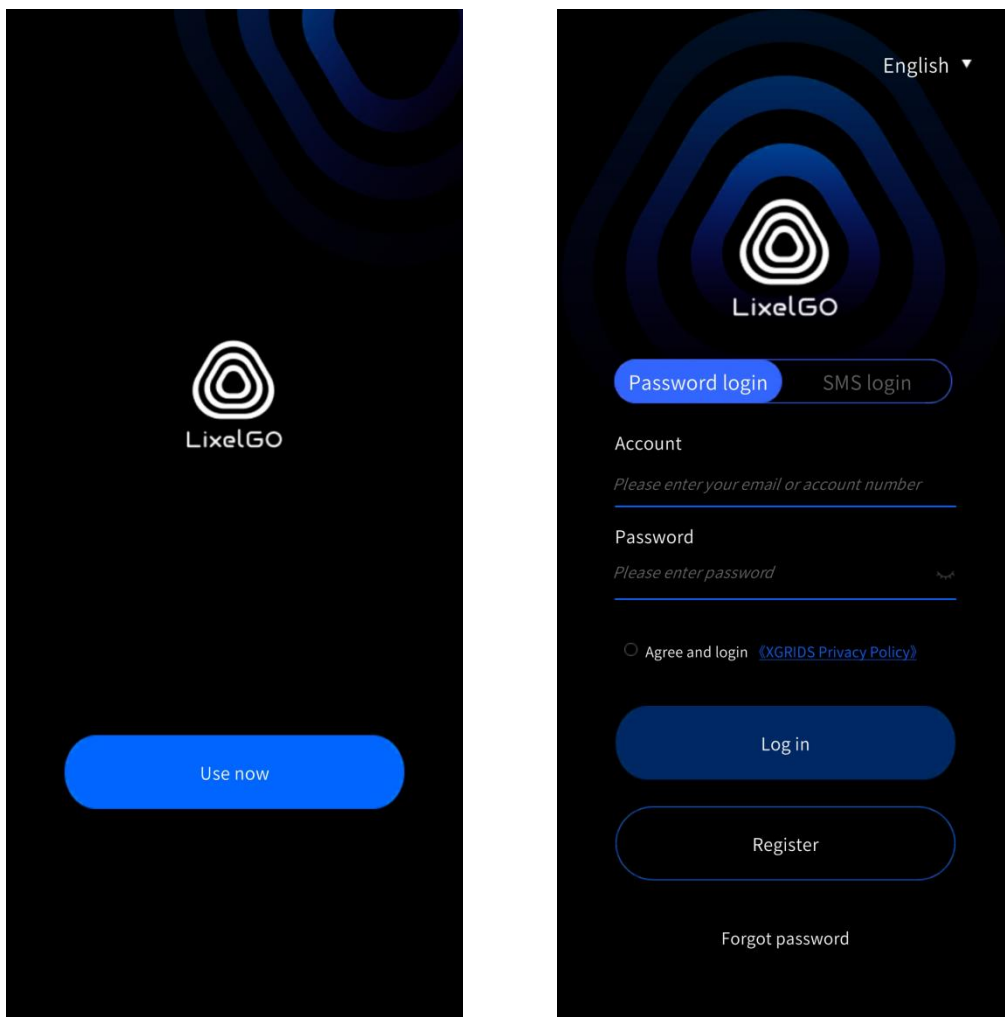

2. Forgot password

If you have registered an account but forgot your password, you can click "Forgot password" to reset it through the registered phone number or email.

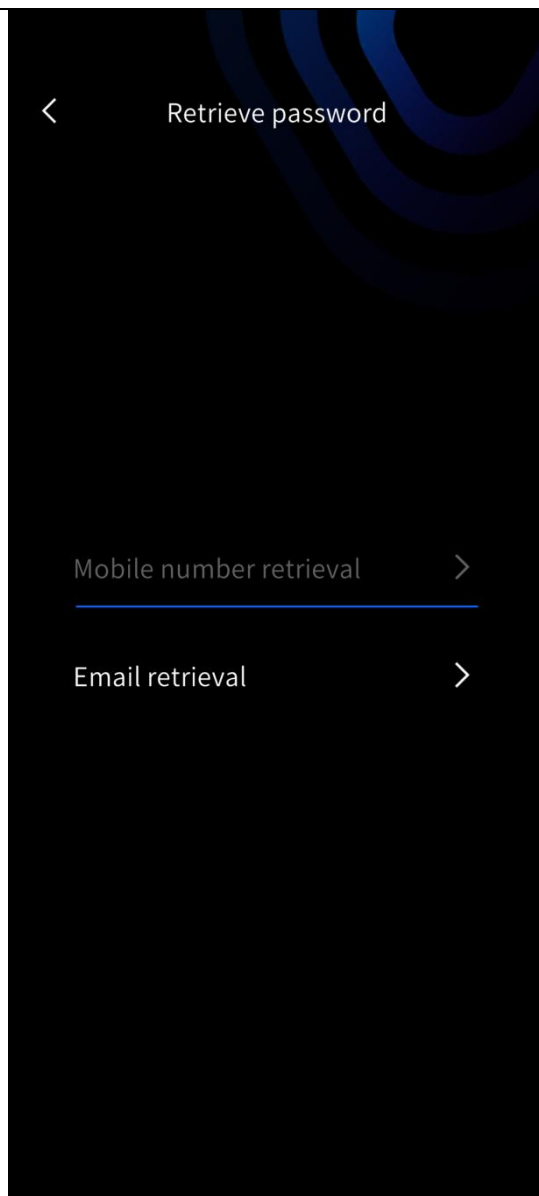

3. Switch language

By clicking on the lower right corner of the screen to setting and switch languages, currently supports Simplified Chinese and English two language modes.



4. Add a new devices

Android version

Press and hold the power button to turn on the handheld scanning device, and the indicator light will flash from blue to green for successful startup.

[Quick Connect Mode:](#)

[Use Quick Connect Mode by default](#)

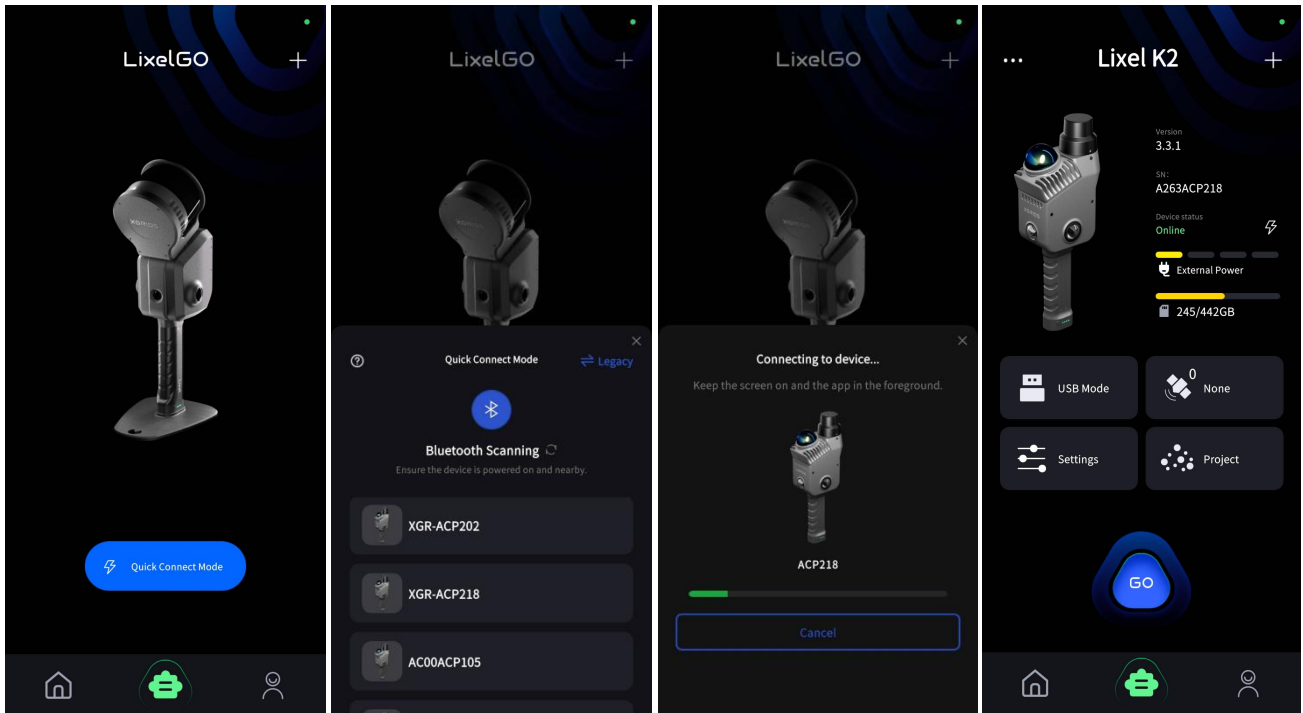

Hotspot Mode:

The first step is to turn on the phone's Bluetooth, search for and connect to the corresponding device's Bluetooth. The second step is to configure the network for the device. Use an SSID and password containing only English letters and numbers — no spaces, emojis, or special characters. This avoids connection failures. Then, enter the hotspot name and password, tap Configure, and the app will automatically connect to the phone hotspot.

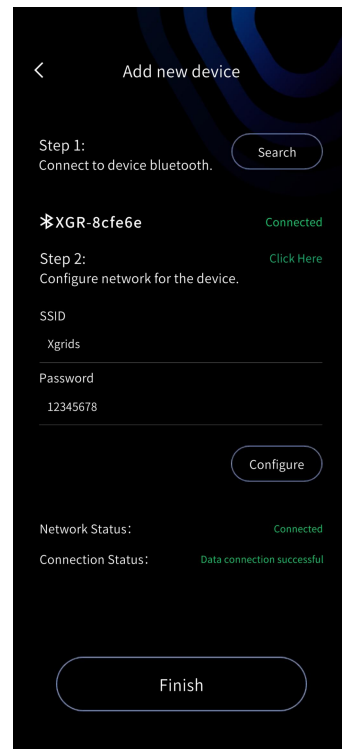
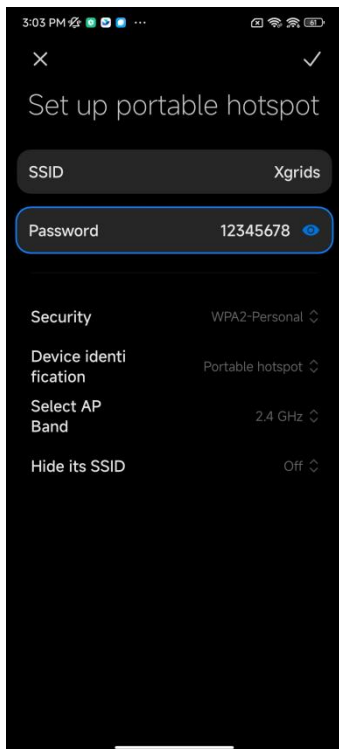
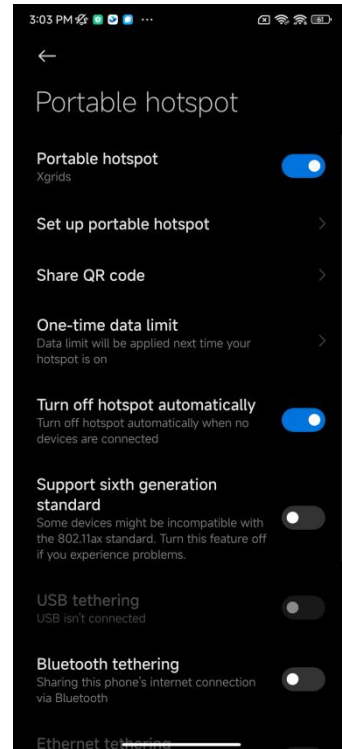
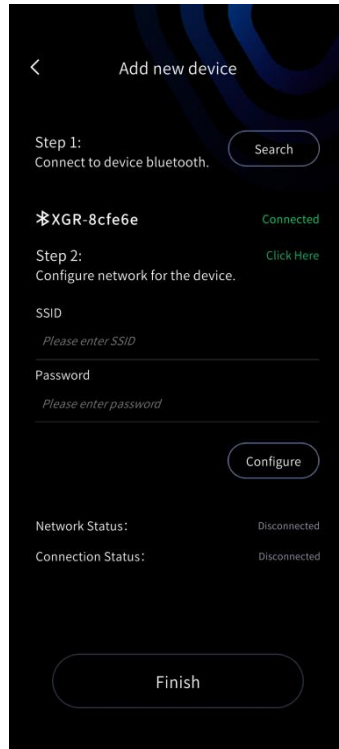
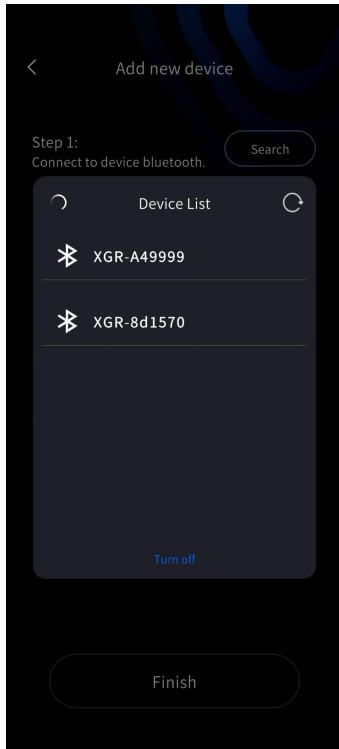

When both the network connection status and data connection status are displayed as successful, click Finish to view the basic information of the currently connected device.

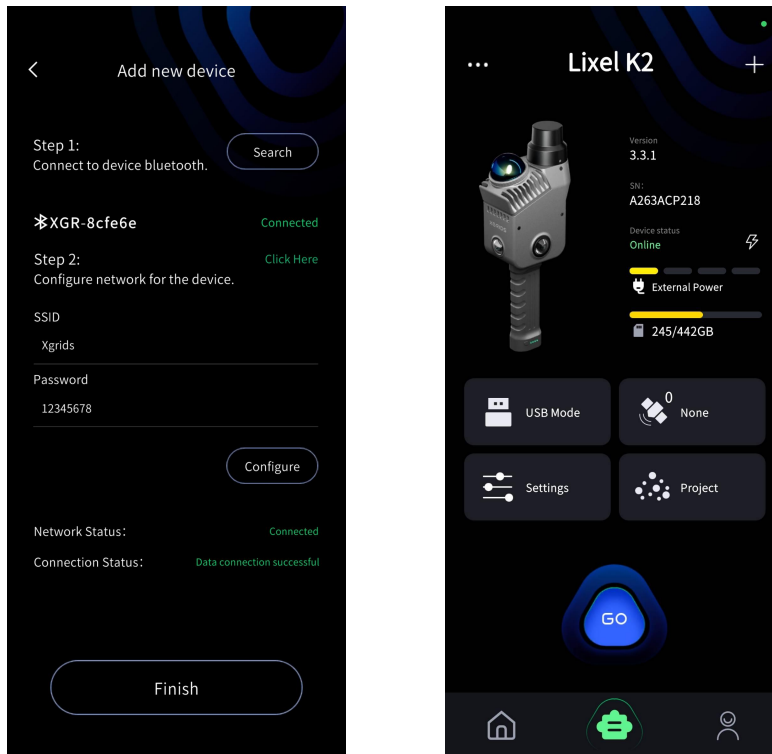

Bridge Mode : Click the plus sign in the upper right corner of the interface, select Bridge Mode, enter the interface, and then follow the operation steps.

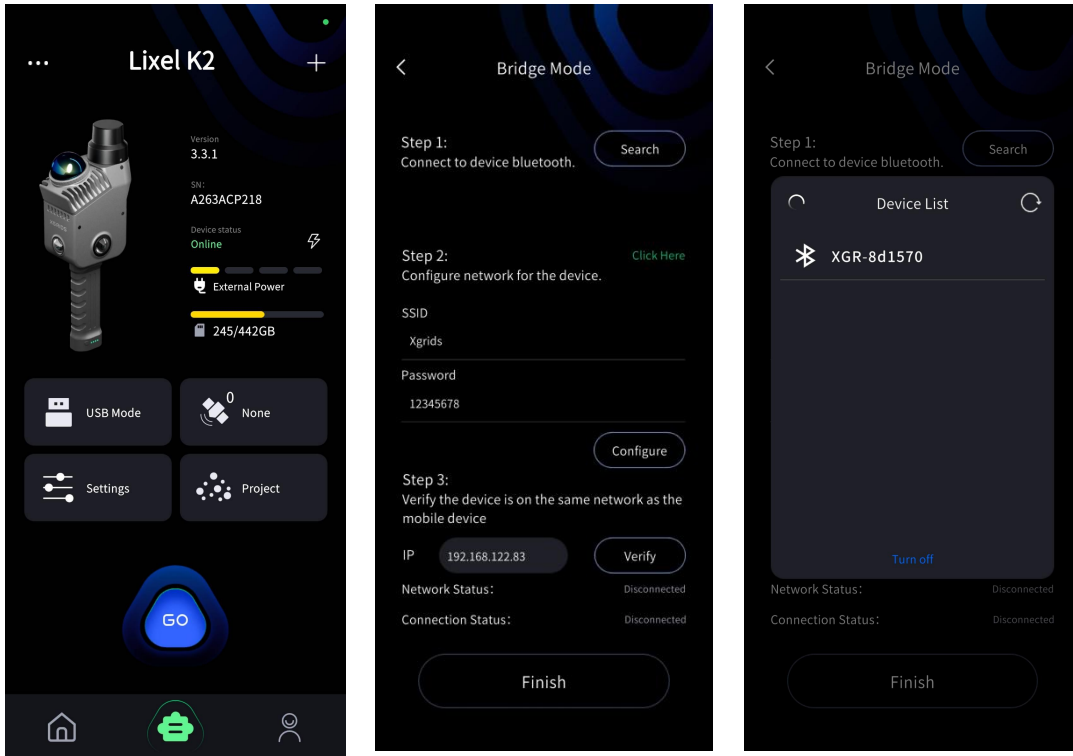

The first step is to retrieve the device's Bluetooth. The second step is to configure the network and verify it. After the correct connection, click Finish to view the device's basic information.

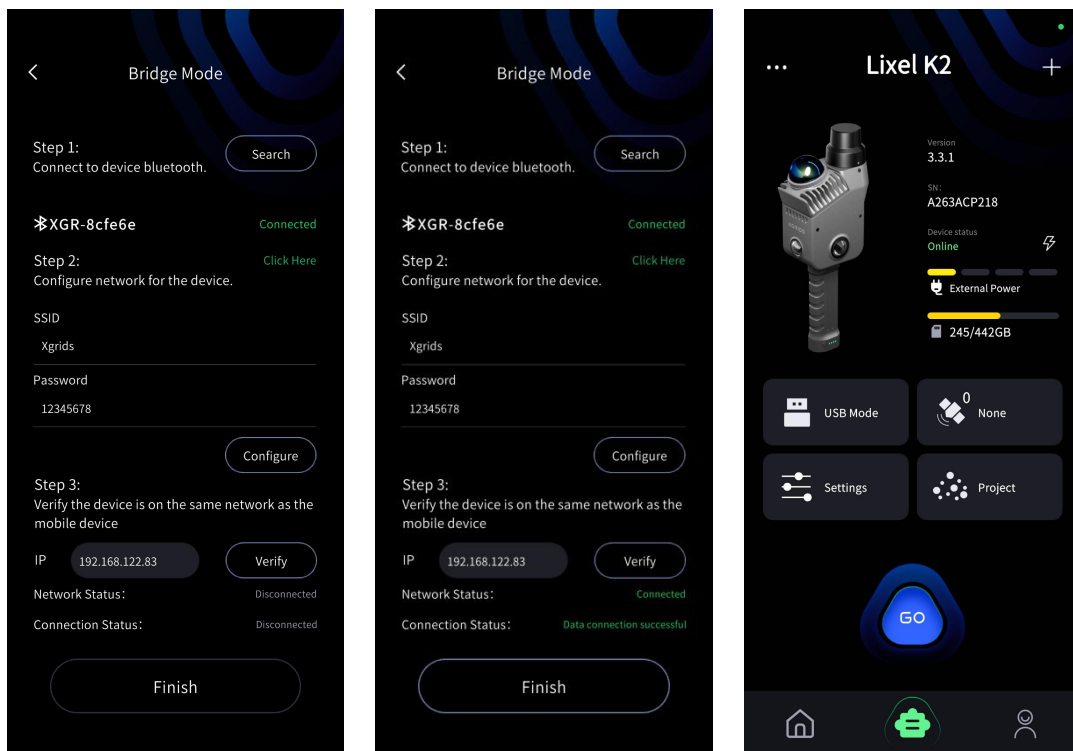

IOS version

Quick Connect Mode:

Use Quick Connect Mode by default

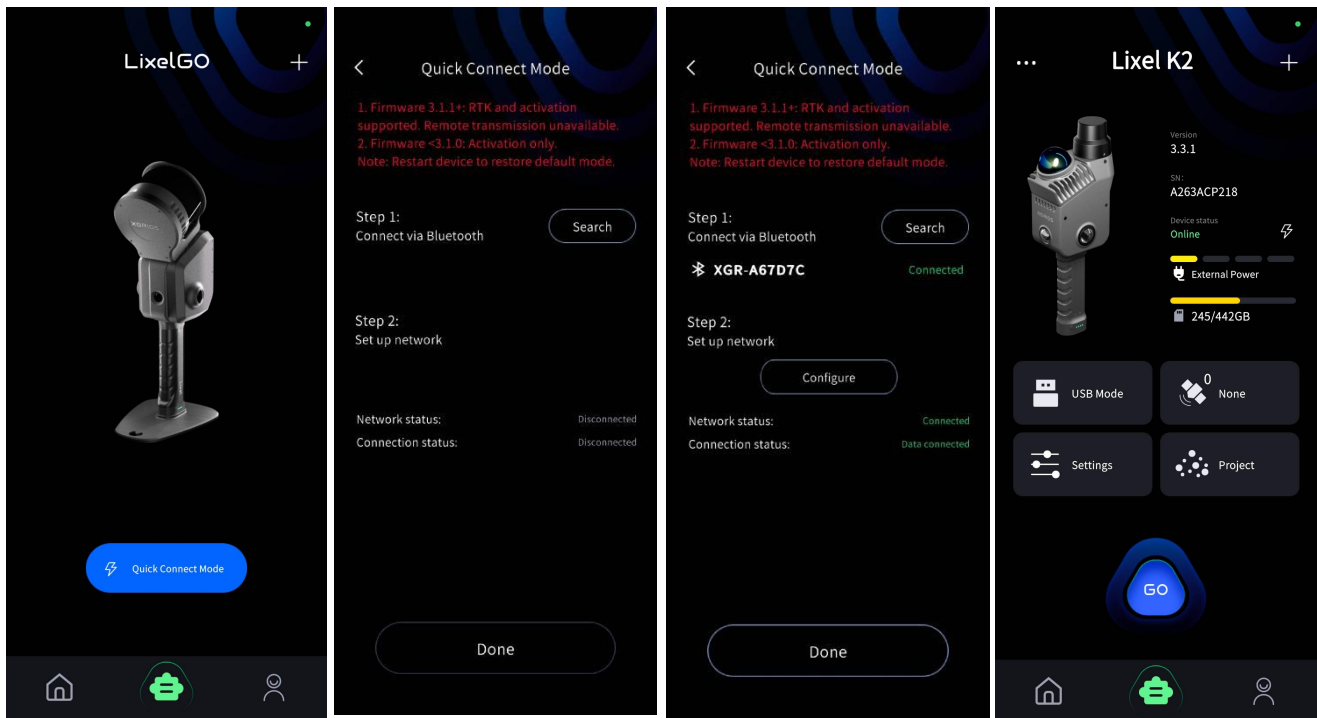

Hotspot Mode:

Before using the app, you need to do some settings for your iPhone first. Click on "Settings" to enter "General," then go to "About." Modify the "Name" field to contain only English characters without using any spaces or special characters. This "Name" is used as the SSID for the phone.

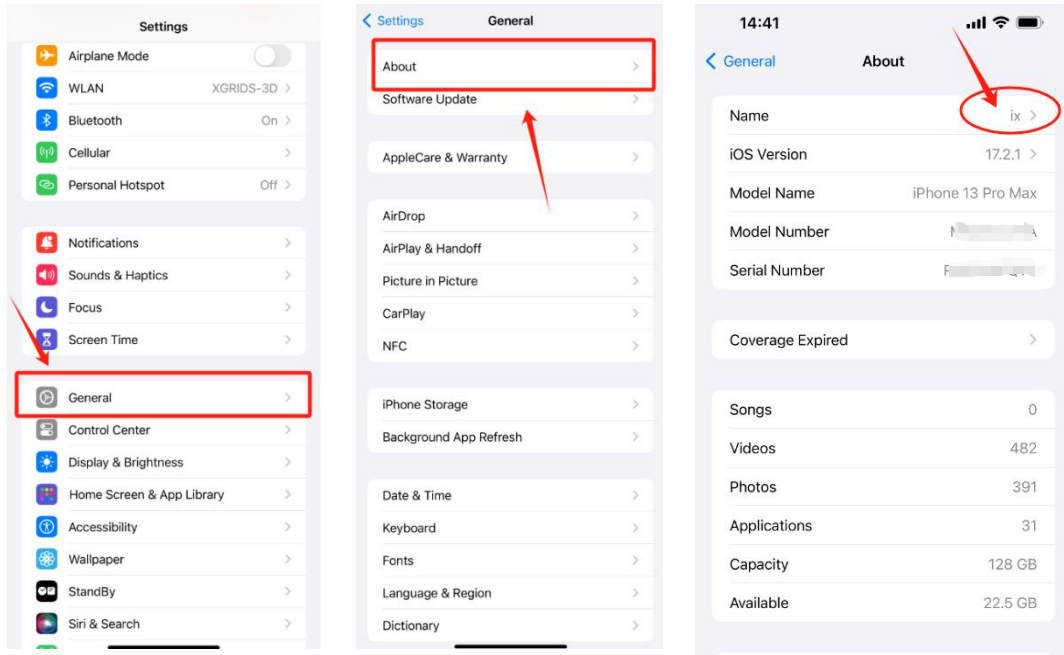

Press and hold the power button to turn on Lixel K2, and the indicator light will flash from blue to green for successful startup.

Direct Connect Mode: Click Add new device, click close, and then follow the steps.

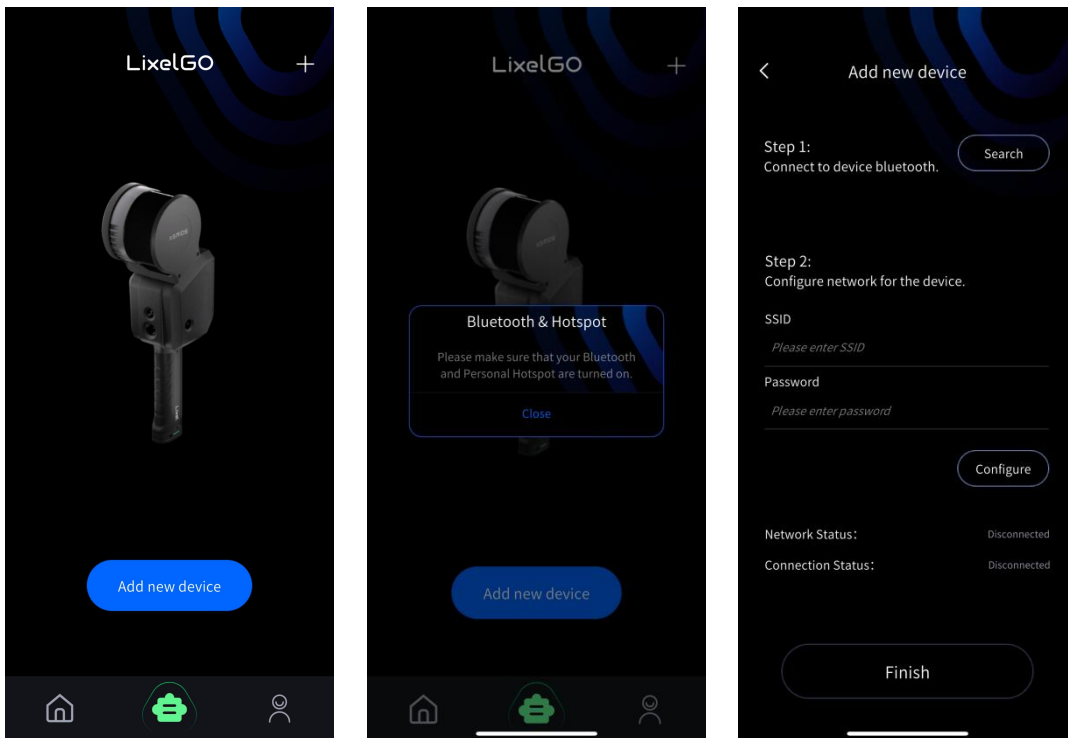

First Time Connection:

Permission requires clicking "Allow."

Select "WLAN & Cellular."

Permission requires clicking "Allow."

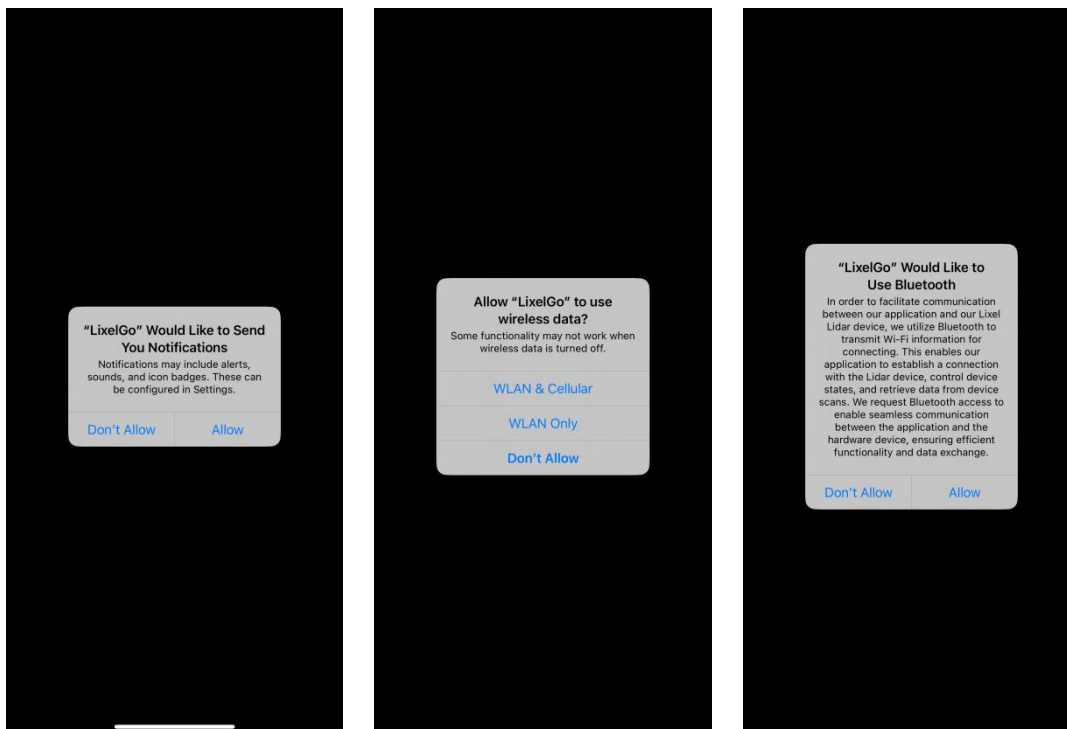

Turn on the phone's Bluetooth, search for and connect to the corresponding device's Bluetooth. The second step is to configure the network for the device. Enter the device name of your iPhone and the password of your hotspot. Set the password as simple as possible. Click on Configure, read the tips carefully.

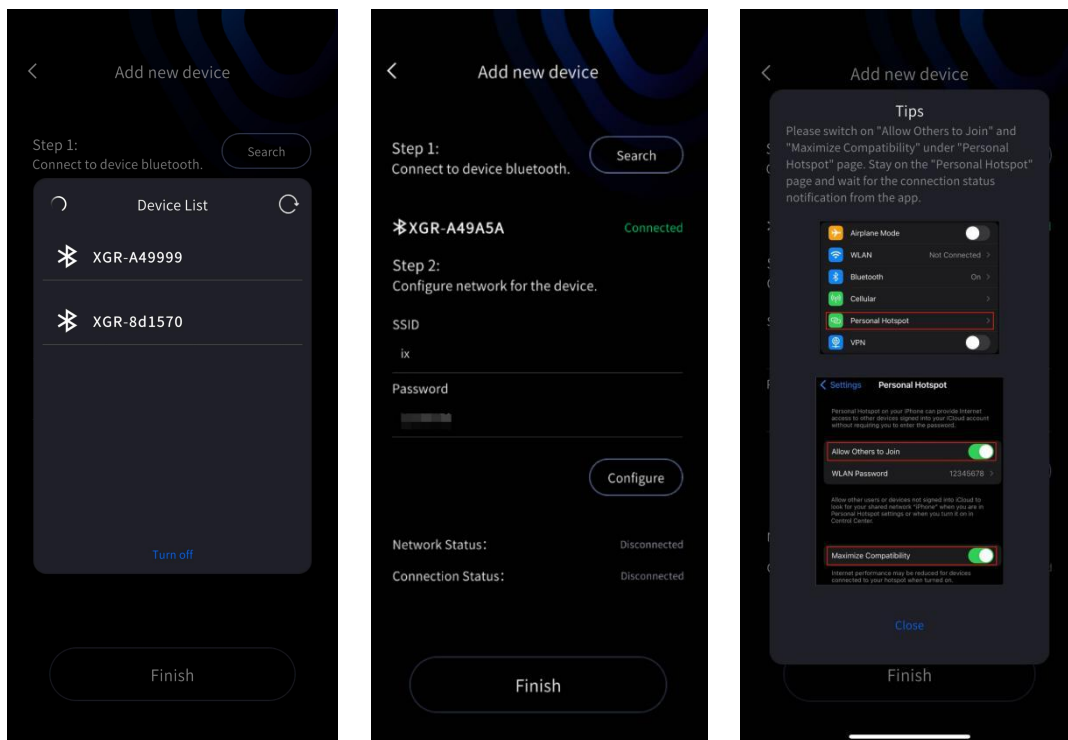

When enabling the hotspot, cellular data (mobile network) must be turned on. (Changing the Wi-Fi connection status will affect the hotspot toggle.)

Only when staying on the "Personal Hotspot" page can you confirm that the phone hotspot is enabled. Also, ensure that the "Allow Others to Join" toggle is switched on to allow devices to connect and discover the Wi-Fi. The hotspot selection must be set to maximum compatibility for successful connection.

Staying on the "Personal Hotspot" page, you will see messages pop out. Only when you see "Data Connection Successful!". You can go back to the LixelGo app.

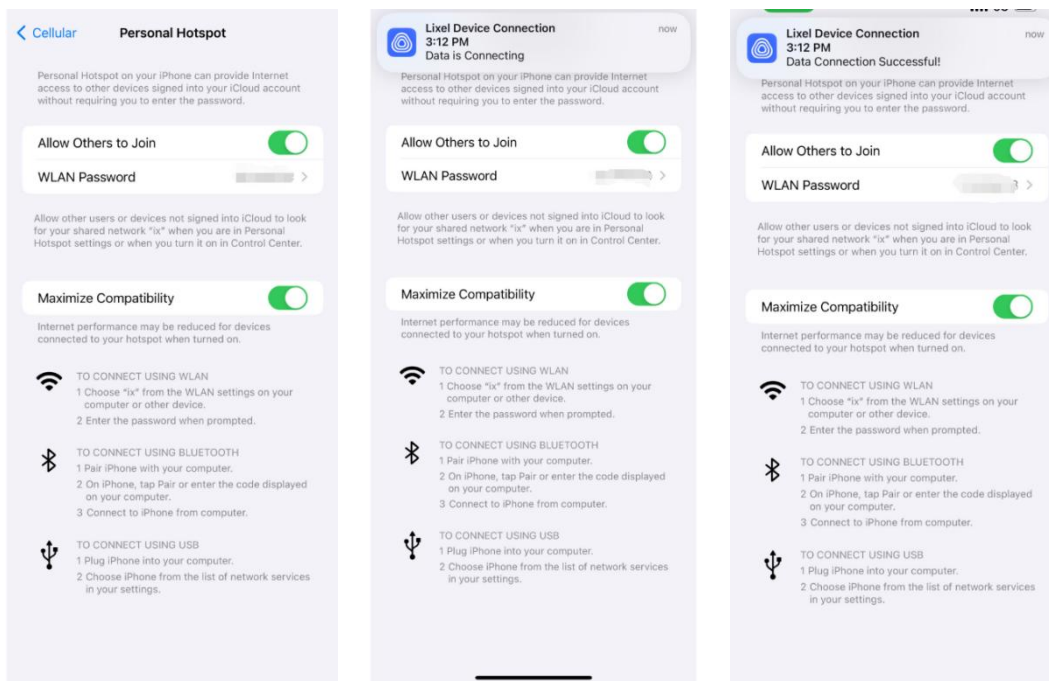

During the first connection, data connection may fail due to permission reasons. After returning to the application, clicking "Configure" will prompt the permission dialog again. Selecting "Allow" will immediately establish a successful connection.

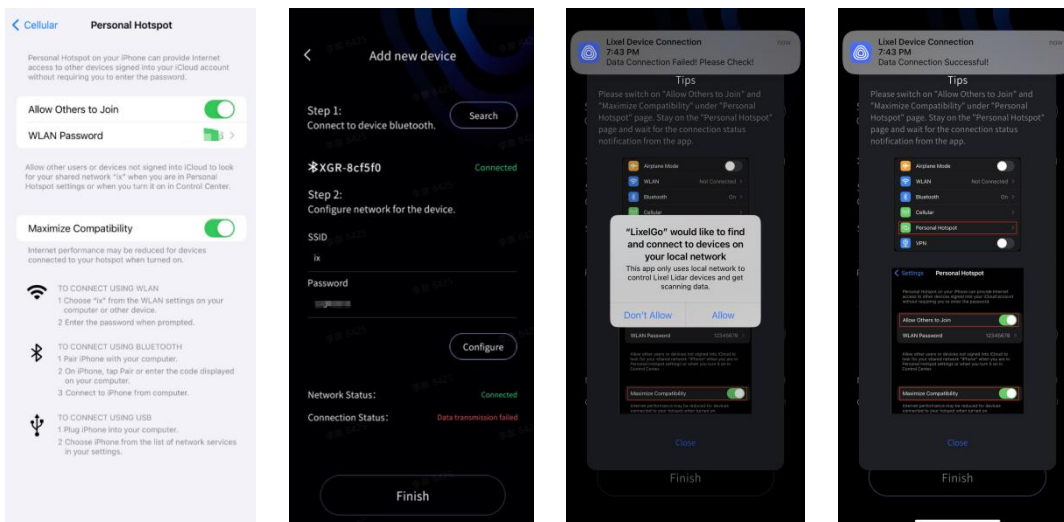

When both the network connection status and data connection status are displayed as successful, click Finish to view the basic information of the currently connected device.

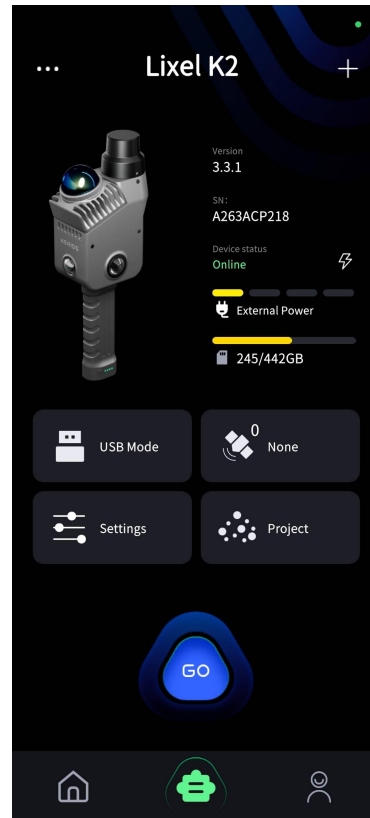
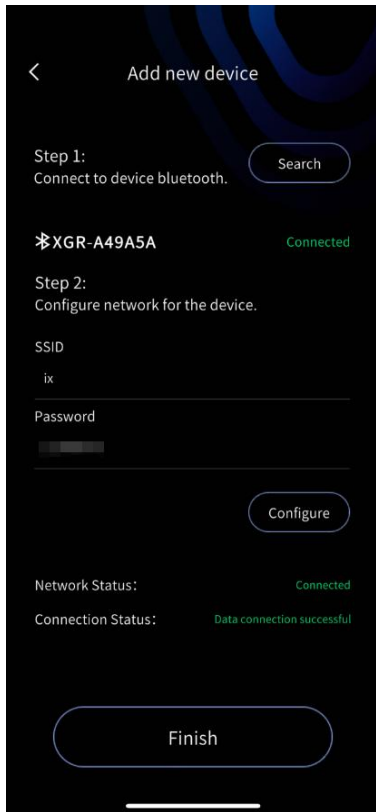

Bridge Mode : Click the plus sign in the upper right corner of the interface, select Bridge Mode, enter the interface, and then follow the operation steps.

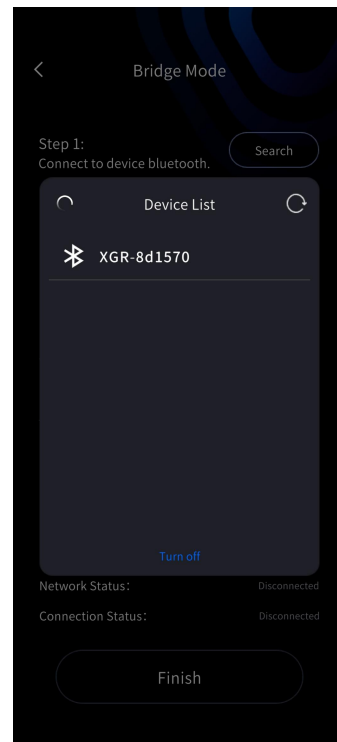
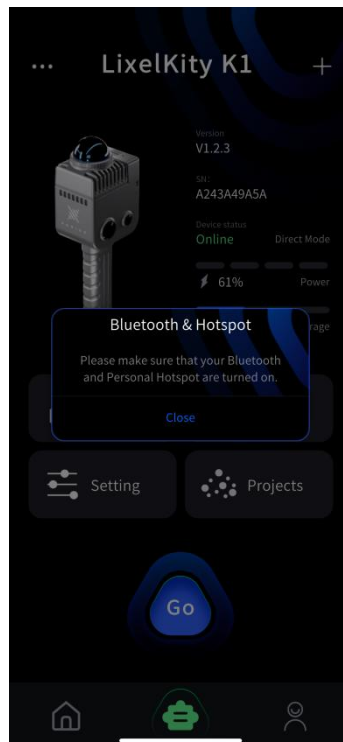
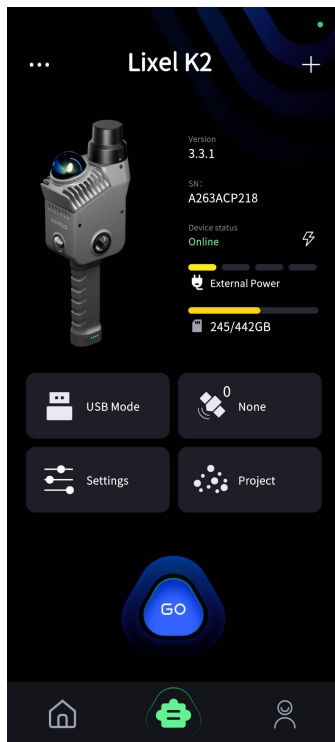

Click "close" and go to the connect page. First search the device's Bluetooth and connect. The second step is to configure the network. See the above steps in direct connect mode for details. After the correct connection, click Finish to view the device's basic information.

5. Device Management

In the device interface, click and pull down the device name at the top of the screen to manage connected devices. Click Remove Device to remove the connection to the device.

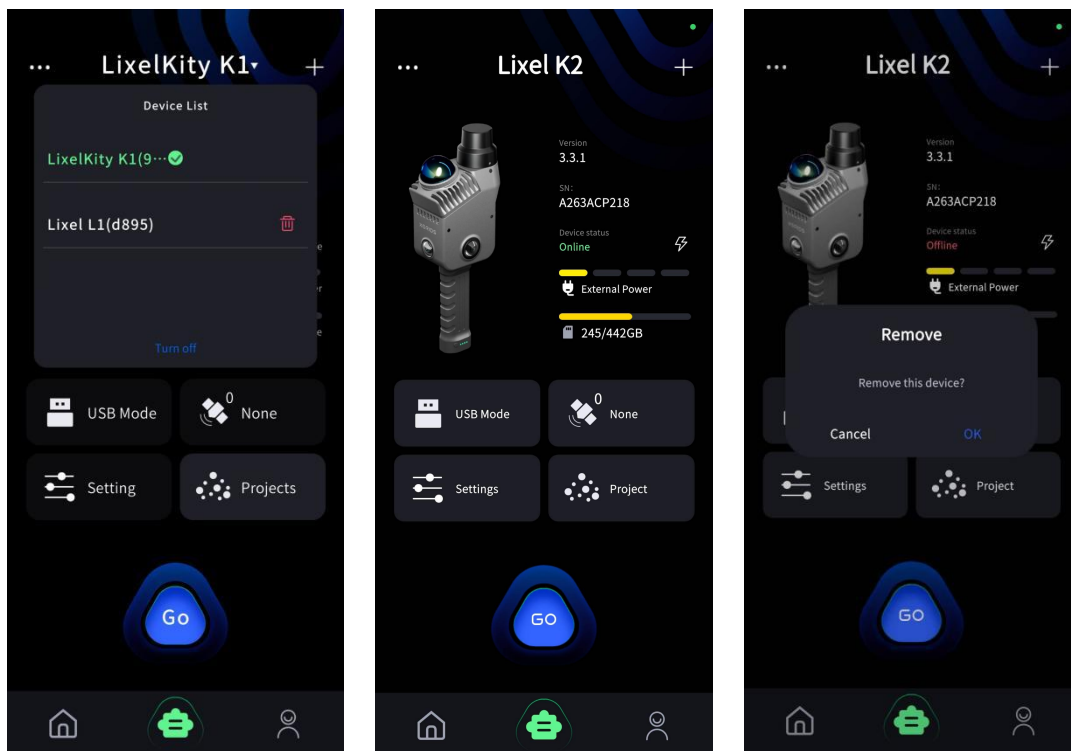

6. Device Activation

Click "GO", and confirm the activation and binding of the device.

7. LixelStudio Activation Code Request

After device activation, LixelGO opens the LixelStudio activation code request form so you can request your LixelStudio code directly. If you cancel, you can re-enter the

request flow via Me → Personal Info → Request LixelStudio Activation Code.

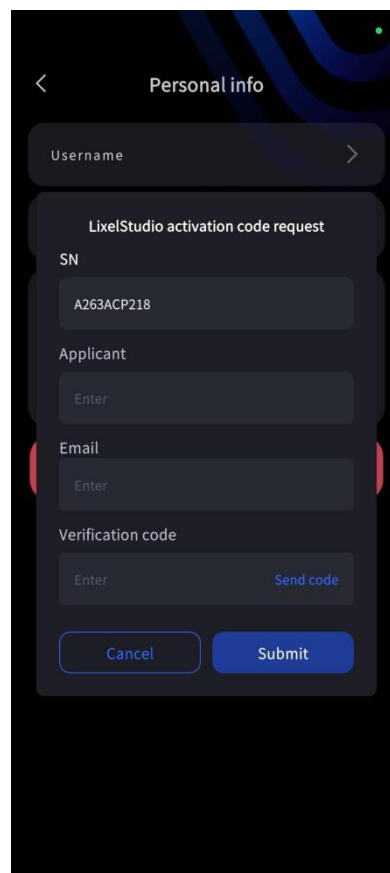
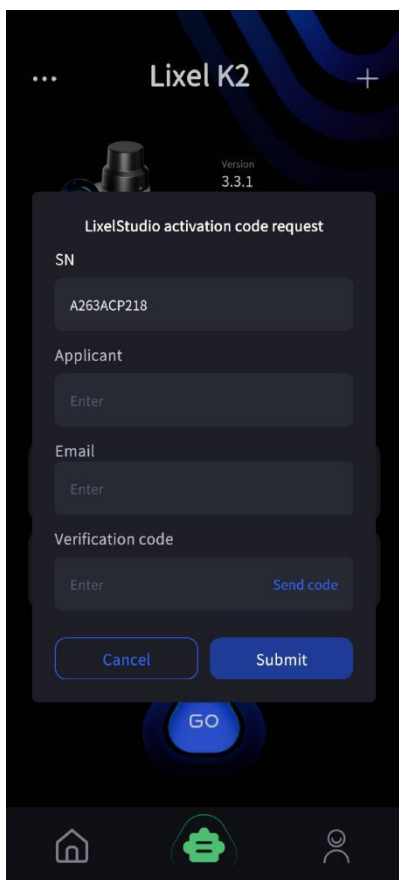

4 Scanning workflow

4.1 Connect the device

Click "Go" to enter the scanning windows so that the device is to be started.

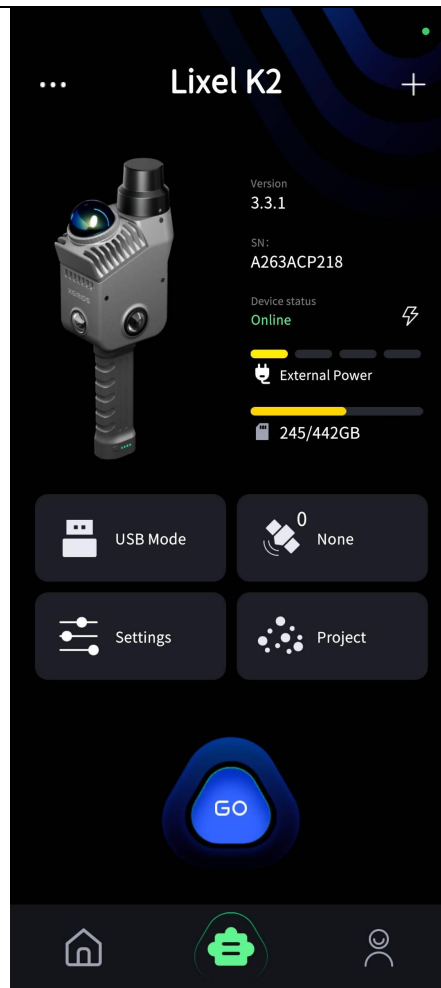

The device undergoes time calibration before leaving the factory, but if it is stored for an extended period, the device's time may become inaccurate. The automatic synchronization switch in LixelGO is turned on by default, which will automatically synchronize the device's time with the time on your phone. Users can also customize the device's time settings through LixelGO. It is recommended that the device's time and time zone match the actual time and time zone of its location.

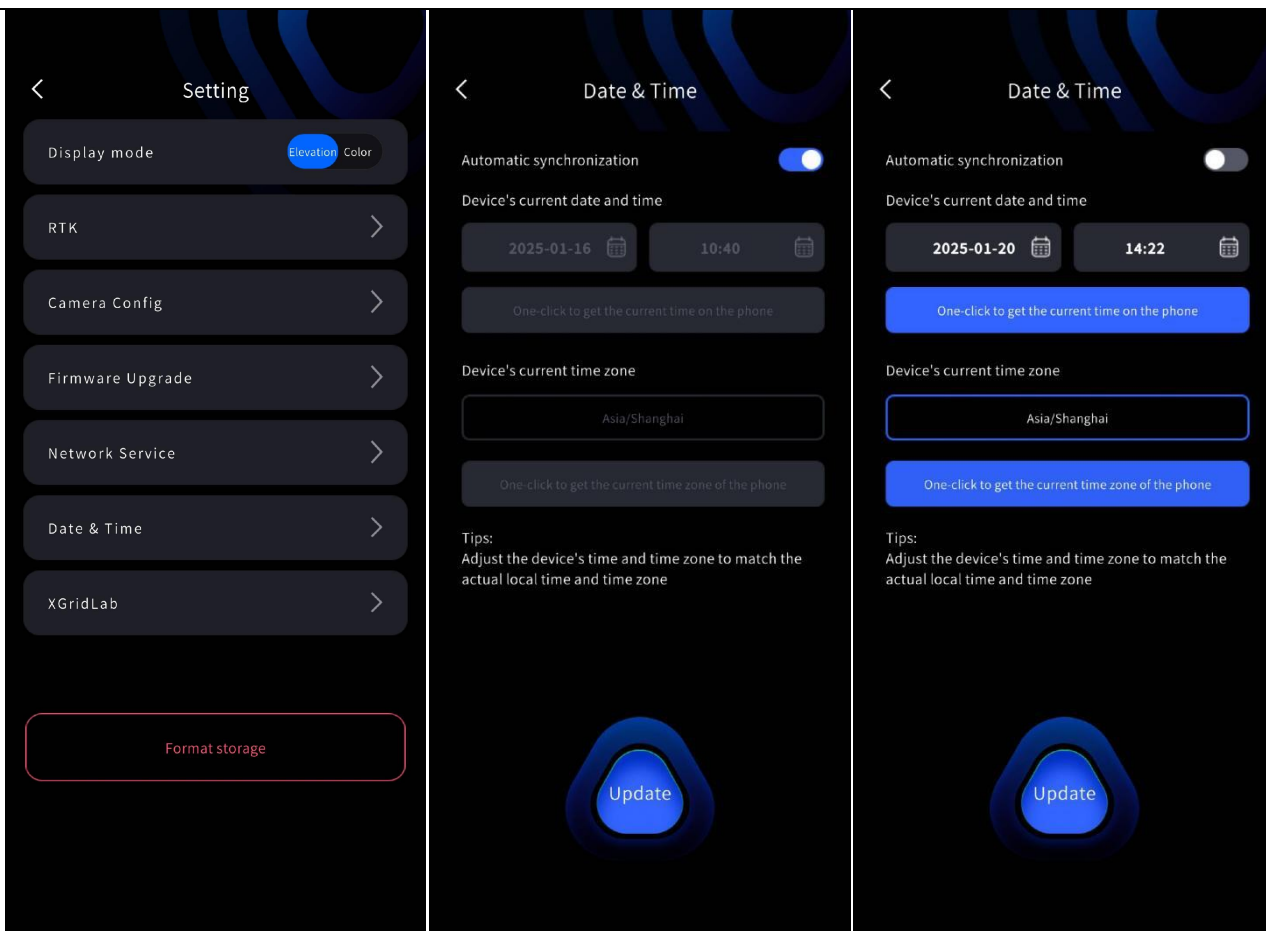

4.2 Scan Mode Settings

Click the red Record button on the right side of the screen and select the appropriate configuration.

GNSS Mode Settings	Function Definition	Description
RTK	The RTK module uses RTK functionality to receive differential data and record it in the project file.	On the startup page, select the RTK mode according to the project requirements. LixelStudio software requires an RTK module for project processing.

PPK	The RTK module uses PPK functionality to receive raw satellite data and record it in the project file.	On the startup page, select the PPK mode according to the project requirements. LixelStudio software requires a PPK module for project processing.
-----	--------------------------------------------------------------------------------------------------------	-----------------------------------------------------------------------------------------------------------------------------------------------------------

Mount Type	Function Definition	Description
Handheld	Use in handheld mode.	LixelStudio will automatically read the mount mode, eliminating the need for manual selection during project processing.

Scan Mode	Function	Description
Guided Mode	Assists users in evaluating scan quality during capture.	Available when Guided Mode is enabled. Supports Scan Assist System and Scan Quality rendering. Does not support true-color point cloud rendering.
RGB Mode	Displays real-time true-color point cloud.	Available when RGB Mode is enabled. RGB mode applies AI extraction and true-color reconstruction; expect ~10 s processing delay for analysis and color optimization. Supports true-color rendering. Does not support Scan Assist System or Scan Quality rendering.

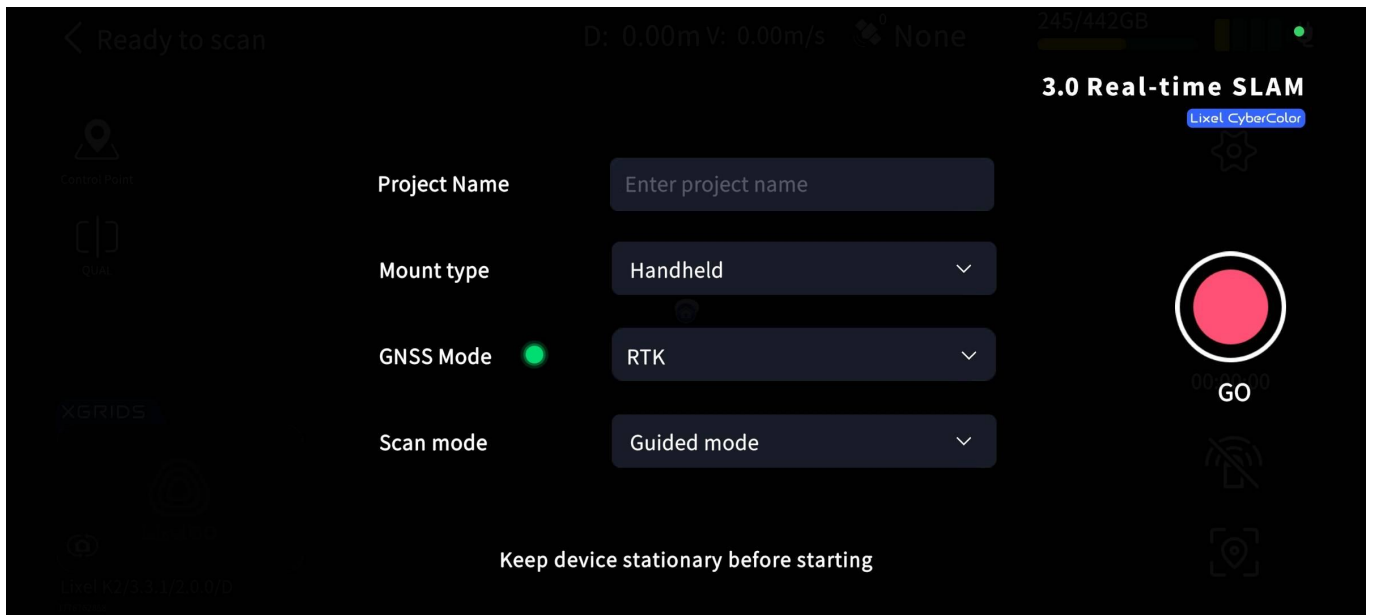

When initiating a scan, an input field for the project name will be displayed on the startup page, and the input field supports multiple languages. If you enter "Parking Lot B2F" and start the scan, after the scan is completed, you will see the project folder named: "Parking_Lot_B2F_2025-01-15-1622026," where "2025-01-15-1622026" represents the scan time. If no project name is entered, the project folder will be named: "default_2025-01-15-1622026."

4.3 Start scanning

After the scanning mode selection is completed, the LiDAR starts working. The indicator light turns green and flashes. And the app prompts that static initialization has started, and then starts a 15s static initialization countdown. During this process, do not move the device to ensure that the device is always in a stable state. After the countdown ends and a pop-up window prompts that static initialization is complete, close the pop-up window, pick up the device, walk around, and start scanning according to the planned route.

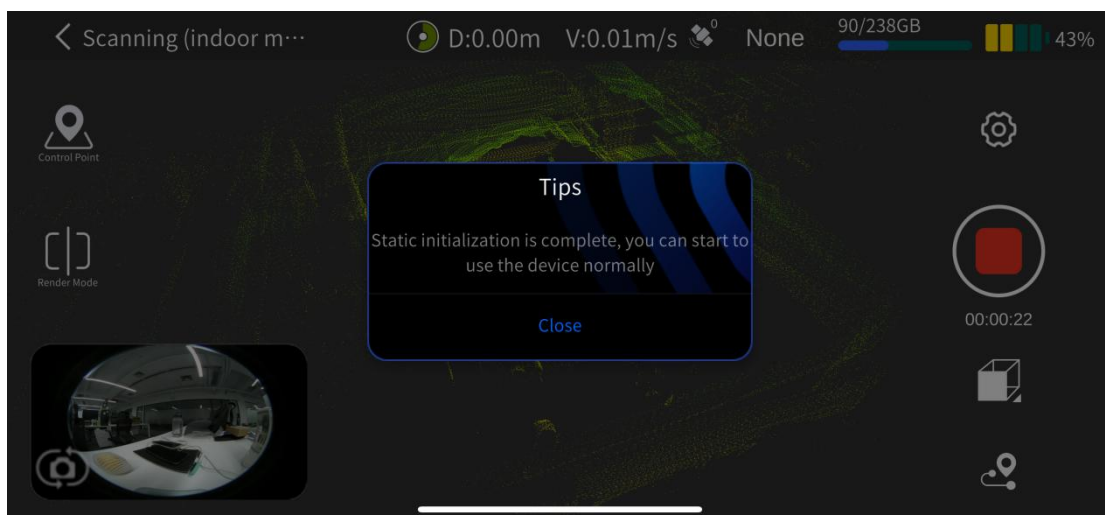
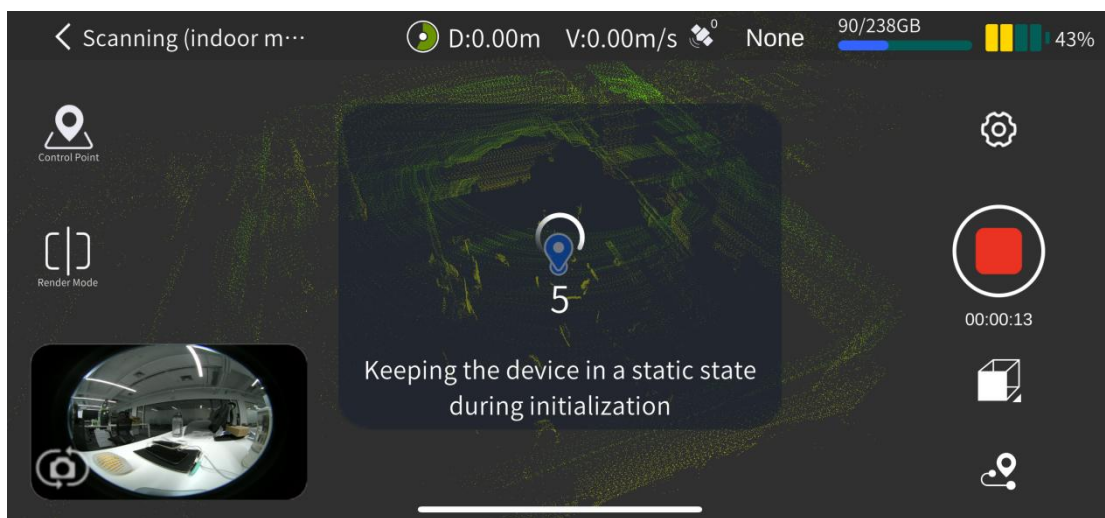
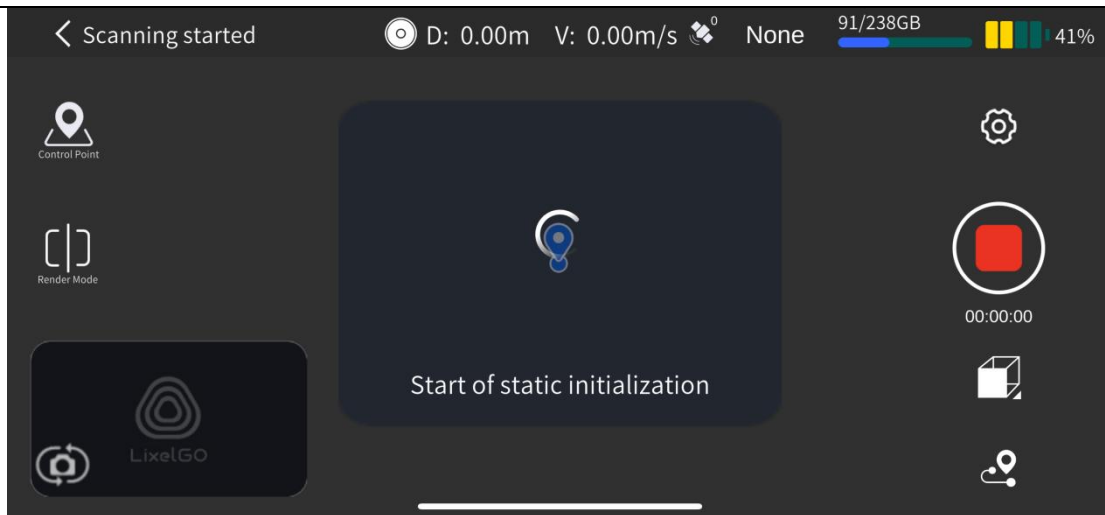

1. Handheld device usage suggestions

Keep the device away from your body while scanning to minimize how much of you appears in the camera field of view — for example, hold it above your head or extended in front of your chest. Reducing the operator's presence in the panoramic camera's

FOV improves colorization quality.

2. Scan route suggestion

When scanning, try to choose a scanning route with a wide FOV. Such as scanning in the middle of the road, which can improve the coverage of the color point cloud and improve colorization accuracy.

When acquiring color point clouds in some small space scenes, such as the gap between buildings in urban villages, narrow roads in alleys, etc, mobile scanning needs to be slower than normal walking, and posture 4 needs to be used if necessary. And it even needs to be scanned in the condition that there are no other shadows or dynamic objects in the scanning process, in order to obtain the correct and better colorization effect point cloud.

4.4 Rendering mode

Tap the Rendering Mode button on the left side of the screen. Depending on your scan mode, three display options are available:

- EL — elevation
- RGB — true color
- QUAL — scan quality

Scan Quality definition: An indicator used to confirm that point cloud density meets the minimum threshold, helping you avoid rework or missed areas caused by sparse coverage. It does not represent scan accuracy, nor does it reflect LCC scan quality.

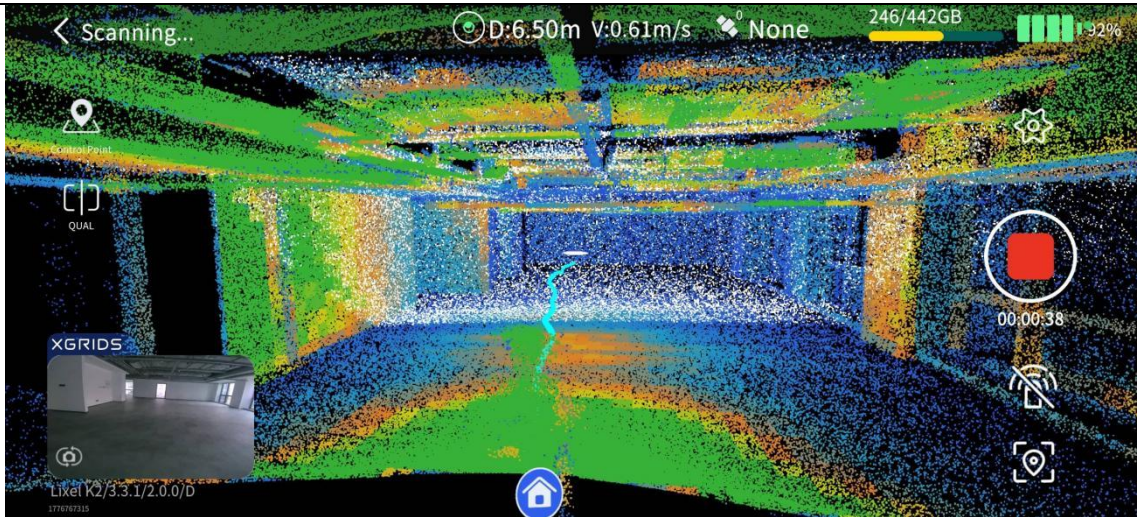

4.5 Scan Assist System

The Scan Assist System is used only to confirm that point cloud density meets the minimum threshold, helping you avoid rework or missed areas caused by sparse coverage. It does not represent scan accuracy, nor does it reflect LCC scan quality.

During a scan, tap Scan Assist System below the stop icon to enable it. Adjust the step distance to match your site in Settings.

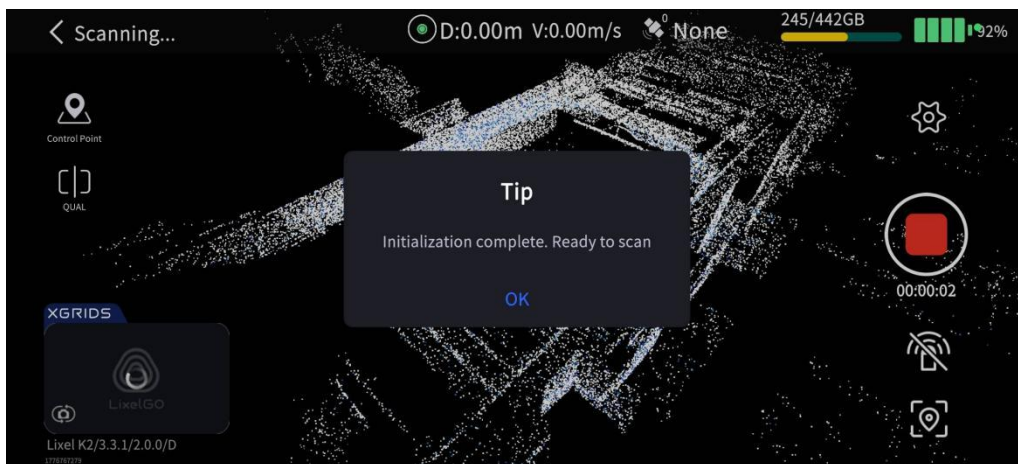

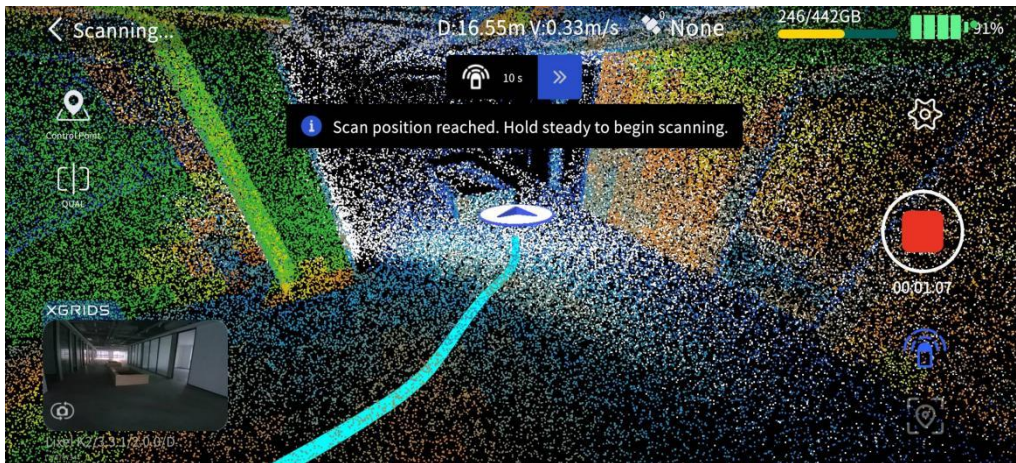
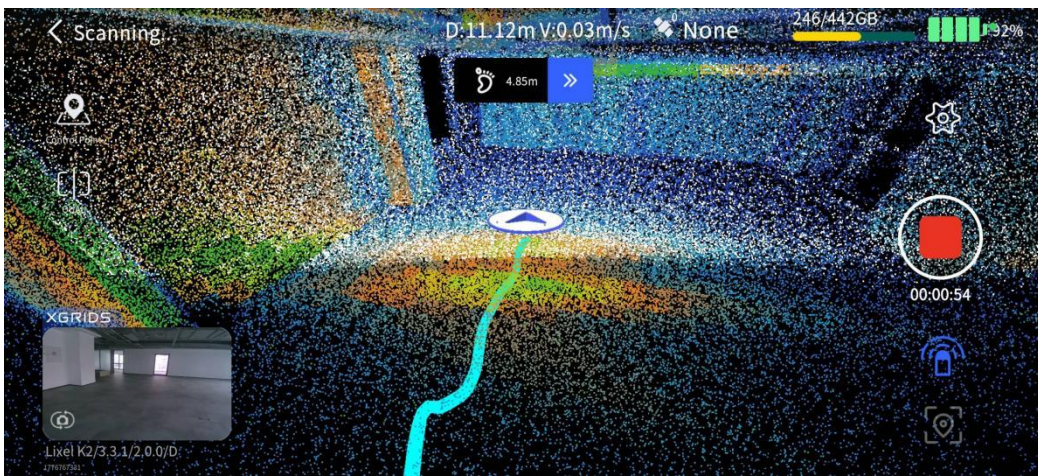
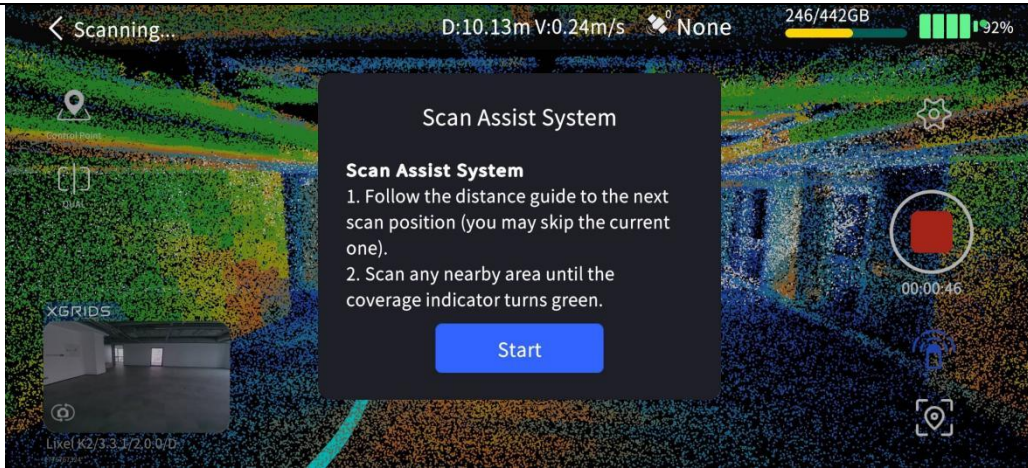

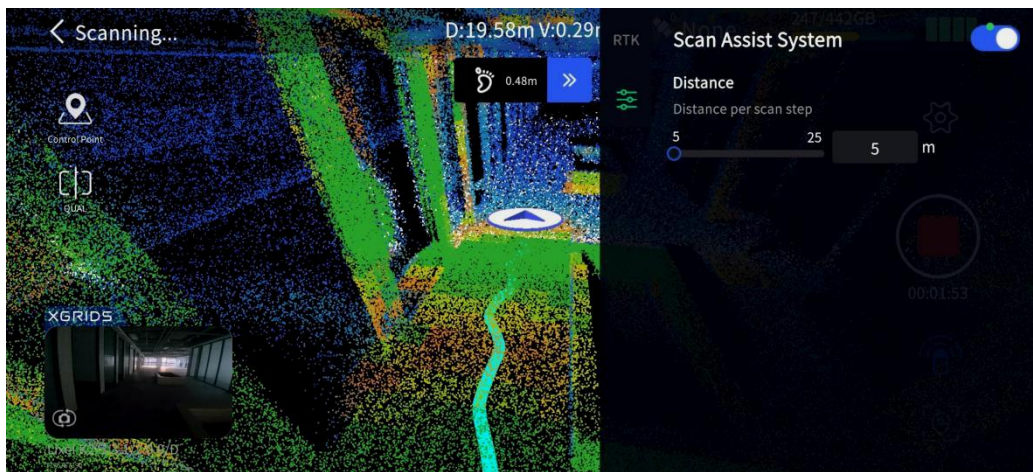
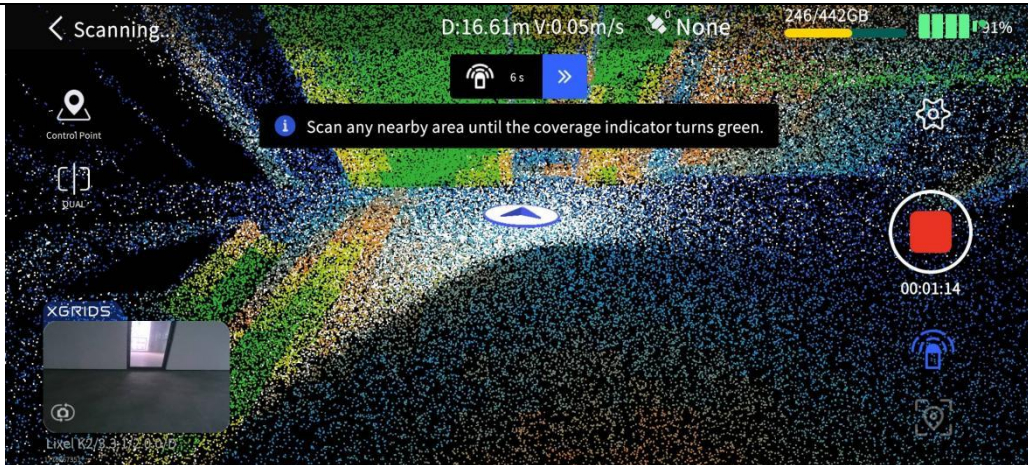

4.6 Stop scanning

Click the red Record button on the right side of the screen. After confirming the stop, the device's green light will flash, and the device will turn green and stay on after the scanning is completed. Then you can shut down the device or start the second scan.

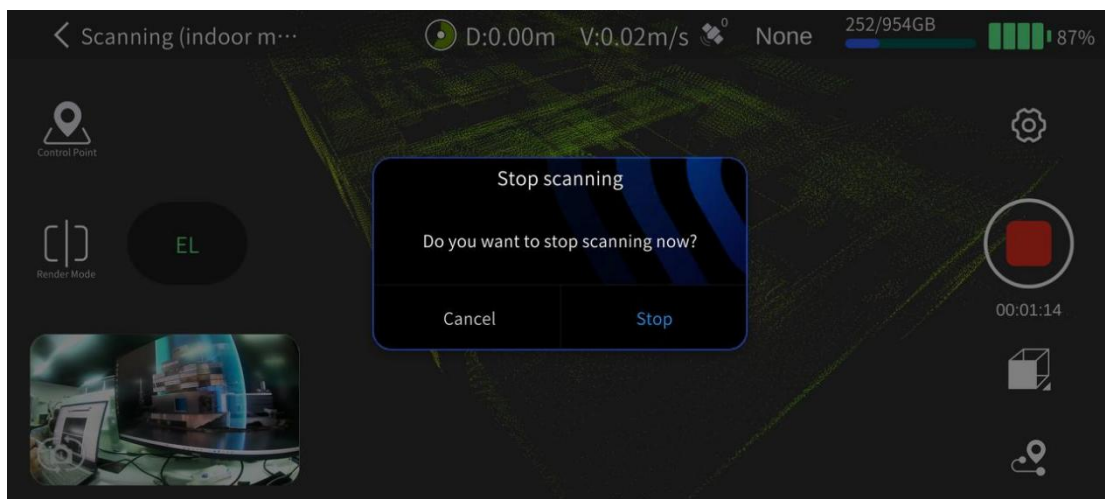

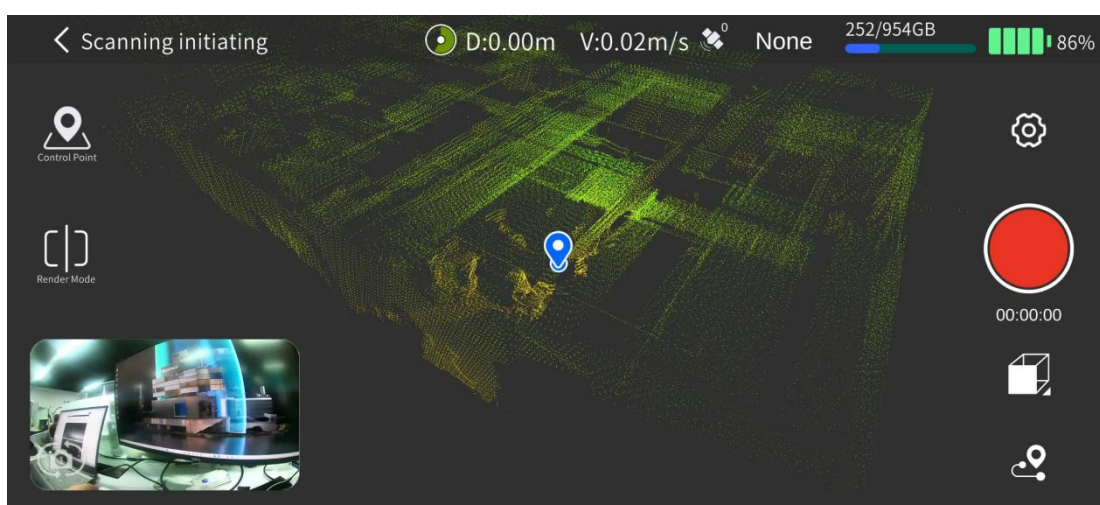
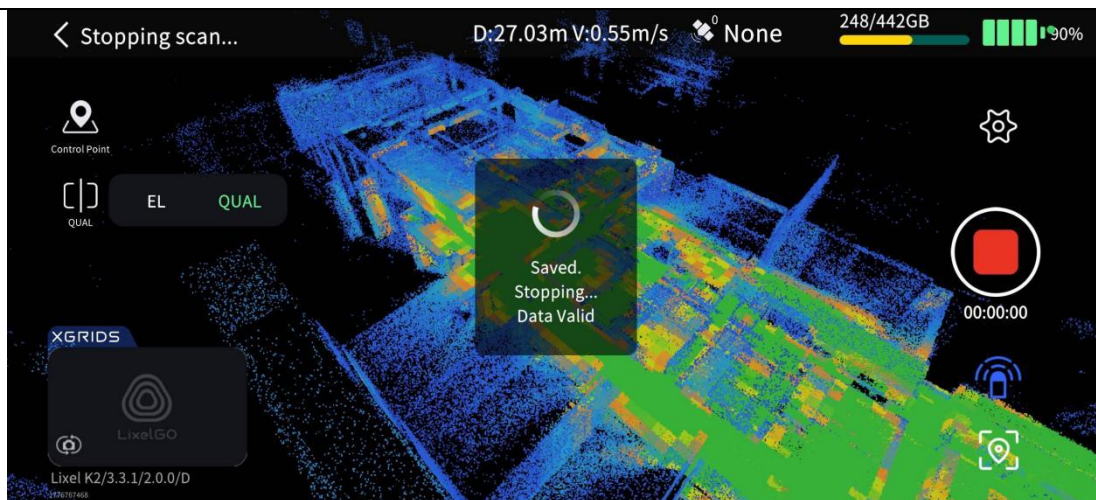

4.7 View Model

After scanning, you can view the scanned model details in LixelGO.

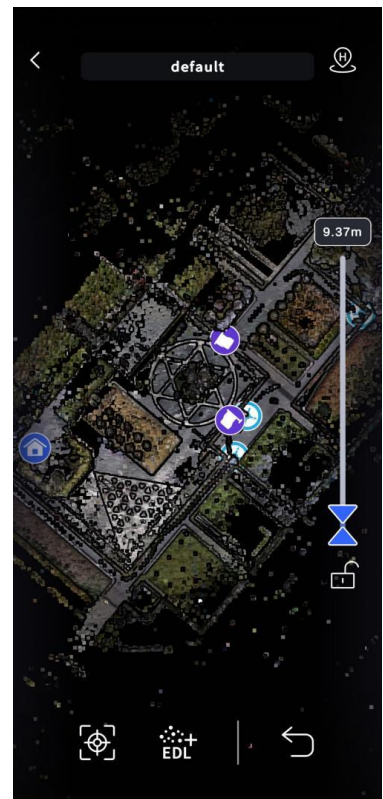
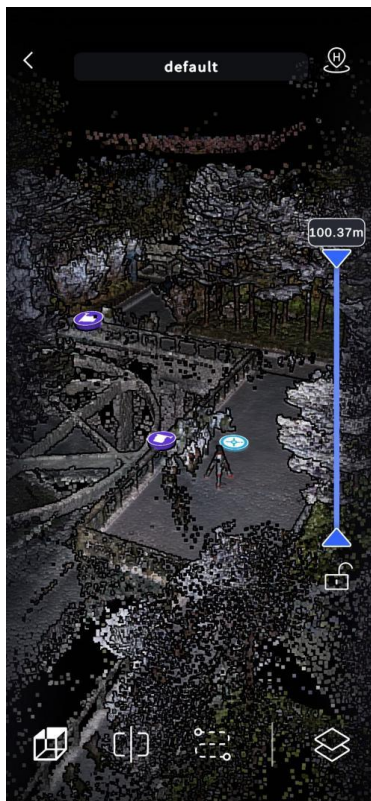
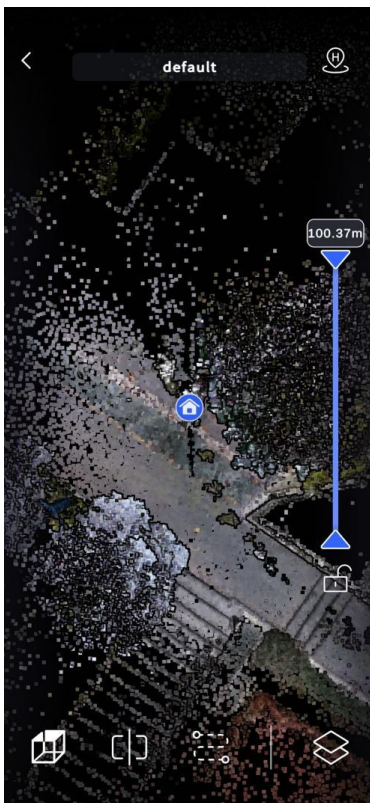
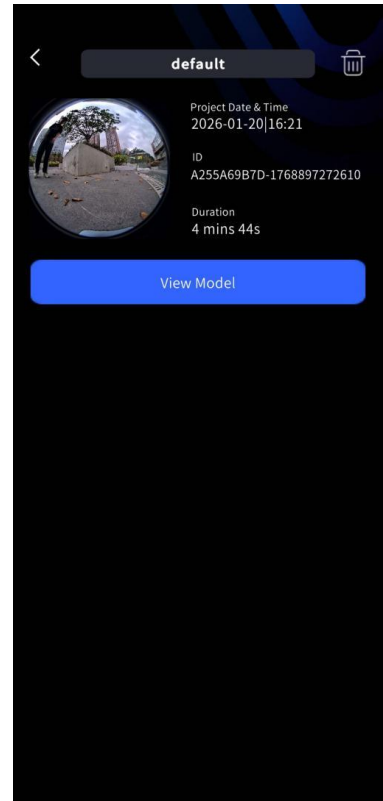
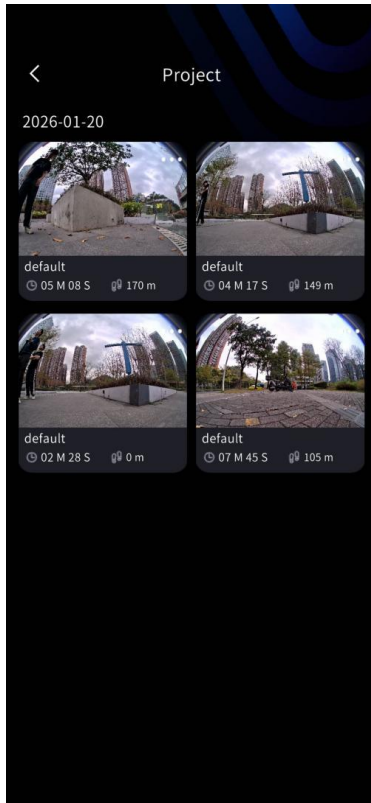
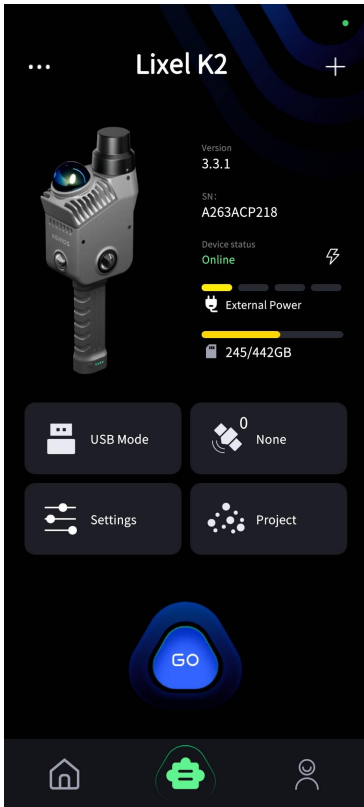

XGRIDS Lixel K2 User Manual

Use the Measure tool in the model viewer to perform linear (distance) and area measurements.

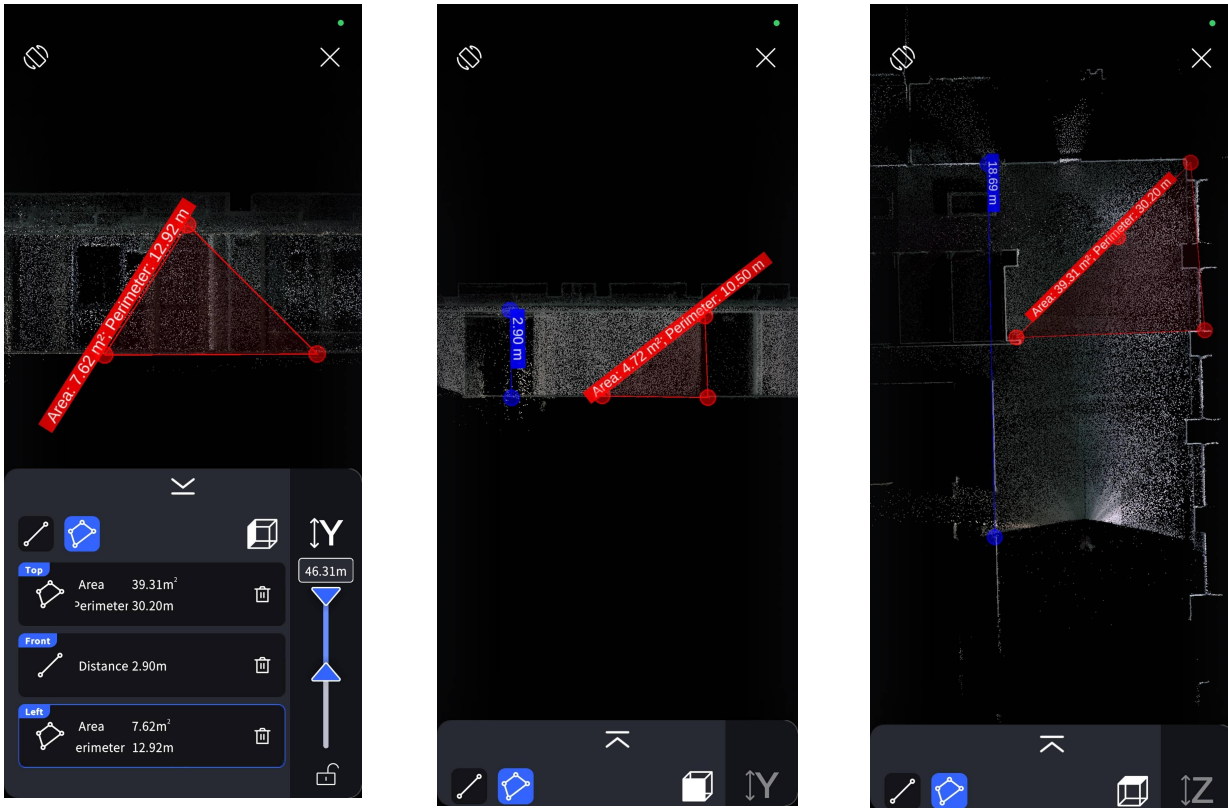

After scanning, share models immediately from LixelGO's Offline Preview module. Shared files are exported as LAS.

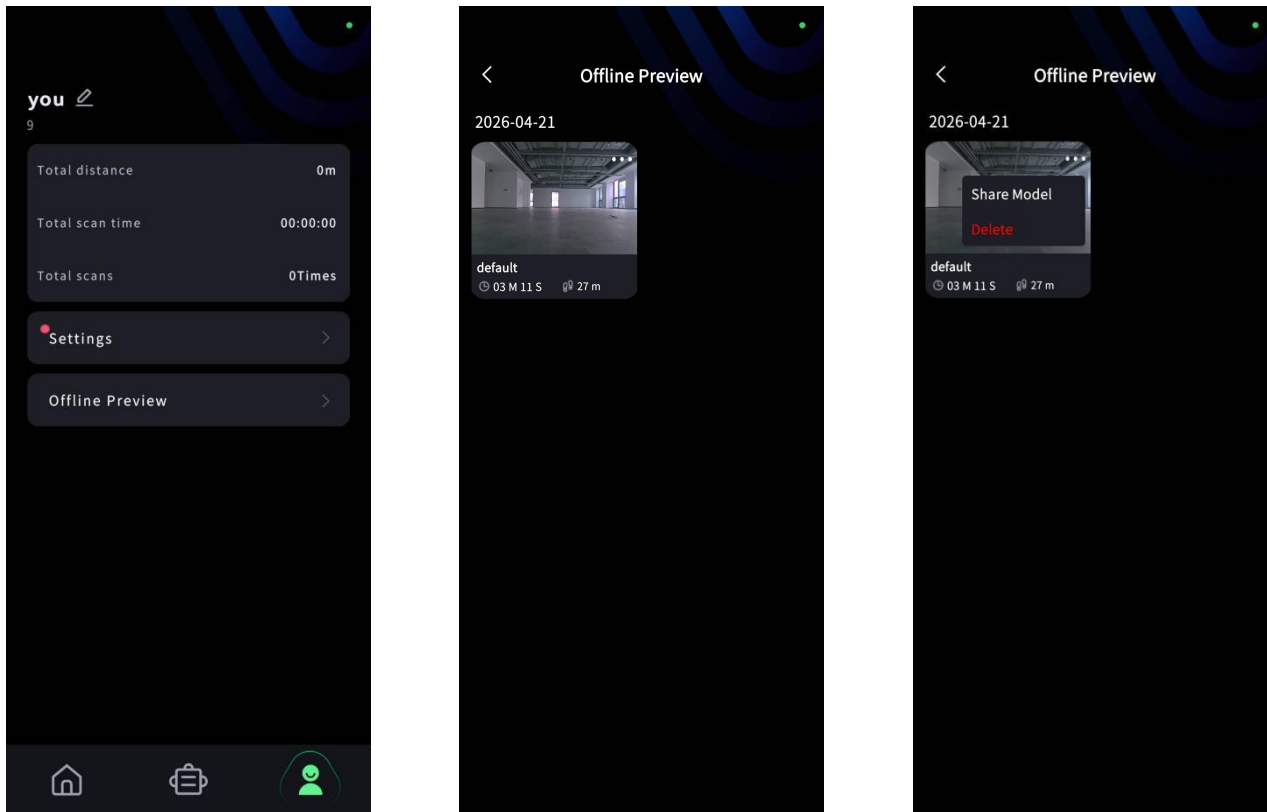

4.8 Downloading scan data

Turn on the device, set the device to USB mode in the app, and then use a Type-C cable to connect the device to the computer.

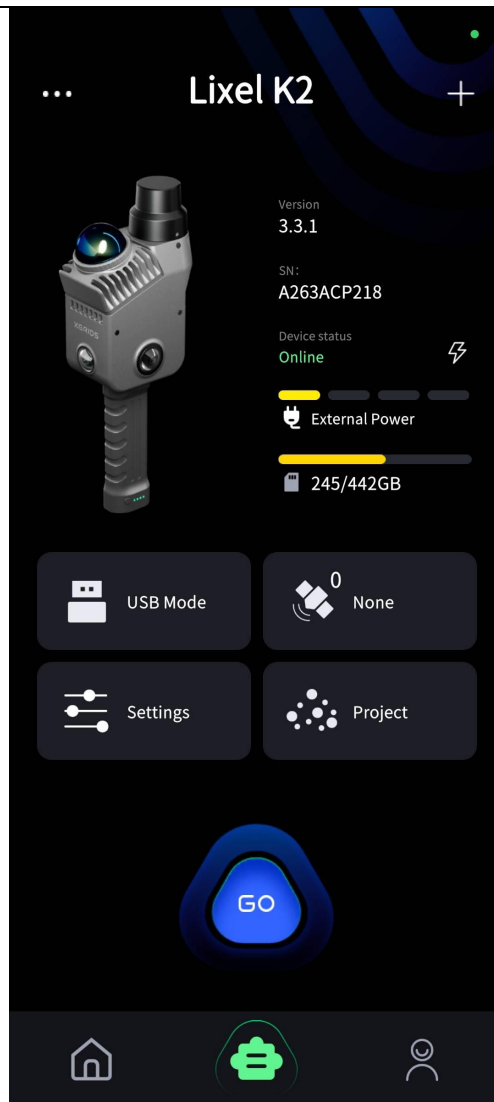





In the model file in the directory of USB disk mode, select the corresponding project file . And you can copy it to the appropriate directory of the computer. The project files name after the time of scan starting: ProjectName-year-month-day-specific time

default_2025-01-16-151347	2025/1/16 15:13	文件夹
default_2025-01-19-122200	2025/1/19 12:22	文件夹
default_2025-01-20-151747	2025/1/20 15:17	文件夹
packing_lot_B2F_2025-01-20-155803	2025/1/20 15:58	文件夹
SMBU_2025-01-19-112340	2025/1/19 11:23	文件夹

4.9 Data project file structure

.hbc is the raw sensor data recorded by the device.

 external_data	2025/6/6 15:28
 project_data	2025/6/6 15:28
 2025-06-06-152838.xbin	2025/6/6 15:30
 map.las	2025/6/6 15:30

File or folder name	Files in the subdirectory	Introduction
xxx.xbin	-	raw sensor data recorded by the device.
map.las	-	the point cloud data directly output by the scanning device in real time.
project_data	control_points.csv	A file that records control point information when using the app to add control points.
	gnss.csv	A file that records GNSS information when using RTK.
	poses.csv	Record the trajectory file during the scanning process.
	project.json	Record device-related information.
	model	In-app model preview file
	photo	Camera image captured when adding a control point
	preview_photo.jpg	Preview photo
	log	The log folder records the relevant log information of the device.
external_data	-	This folder is empty when the data is initially copied from the handheld device. It

		is mainly used to copy and store external file data required for post-processing in LixelStudio, such as video files of external panoramic cameras and gnss.csv files after coordinate conversion.
--	--	----------------------------------------------------------------------------------------------------------------------------------------------------------------------------------------------------

Please note: The direct point cloud data is downsampled. If you need complete point cloud data, please use LixelStudio software for post-processing.

5 Acquire point cloud data with absolute coordinate

5.1 Through existing Ground Control Points (GCP)

You can achieve coordinate conversion through the existing Ground Control Points (GCP) you marked during the scan, by which the accuracy of the point cloud data can be optimized as well.

Note: The number of control points in the scanning area is determined according to the accuracy requirements. And the layout of control points should be evenly distributed. To ensure subsequent coordinate conversion to be successful, at least 3 or more control points reasonably distributed are required for a single scan. The more high-precision control points covered by scanning, and the more evenly distributed, the higher the accuracy will be. Do remember the points cannot be distributed on a straight line.

1.Scanner installation

Your Lixel K2 Handheld Scanner contains in the box: a battery and a control point base.

Installation diagram is as follows:

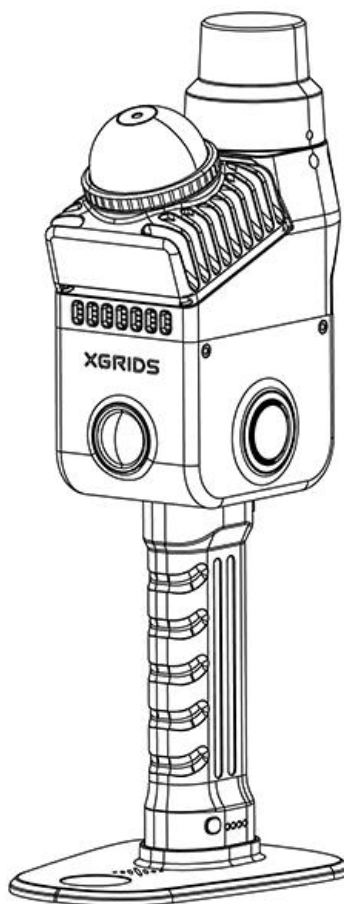

2. Field work: scanning

Field survey and planning

If there is a corresponding topographic map of the scanning area, the control points can be designed according to the map, and the on-site inspection and design can be carried out synchronously. If there is no corresponding topographic map, the design will be carried out according to the on-site environment.

The distribution of control points should be as reasonable as possible, which means evenly distributed in the scanning area. And the distance between control points should be within 50 meters.

According to the distribution of control points and scanning environment, plan a reasonable scanning route.

Start scanning

Turn on the scanner, and start scanning through the LixelGO or the button on Lixel K2. For specific steps, please refer to the Scanning Workflow.

Mark the ground control points (GCP) during the scan

When scanning on the route across the areas covering the control point, align the sharp corner of the front end of the scanner control point base with the control point, and then click to add the control point in the LixelGO.

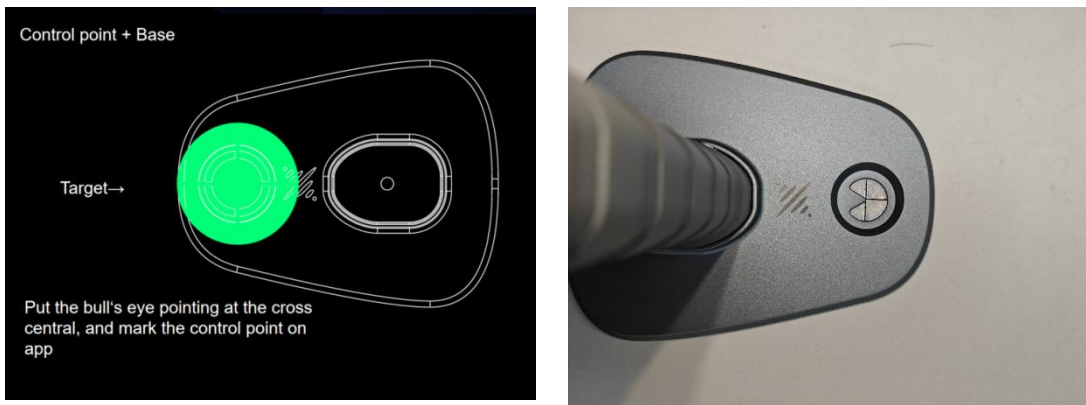

Click "Control Point Mode" on the left side of the screen.

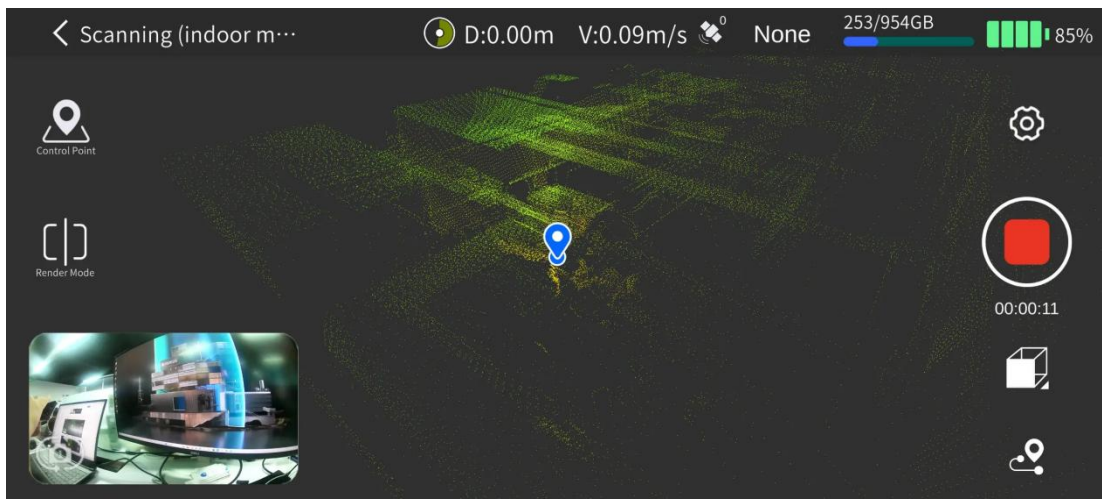

[GCP]Click "+" on the left side of the screen to add a control point.

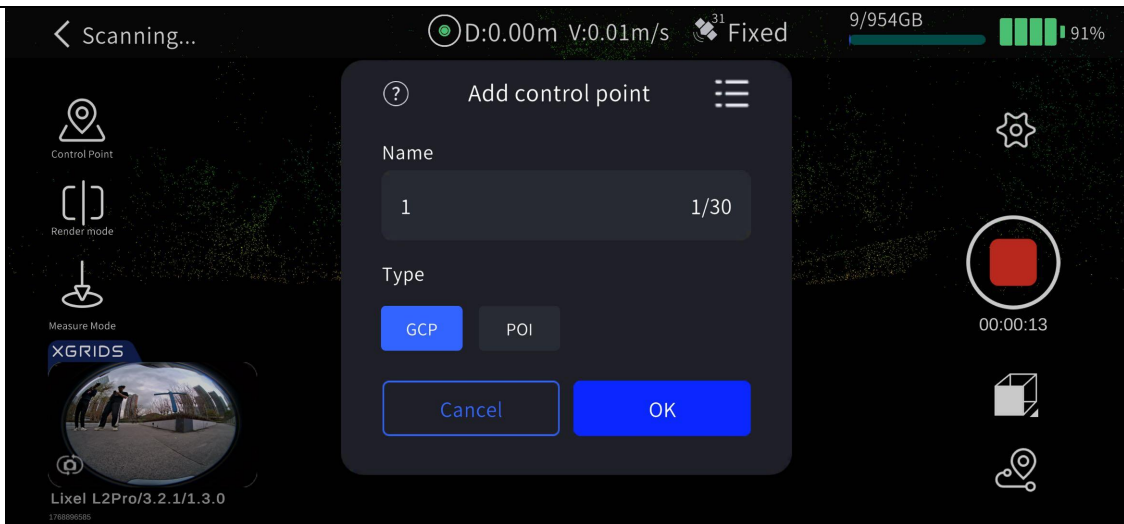

Enter the control point number, then click OK, and the screen will pop up "The control point was added successfully", indicating that the control point was successfully marked.

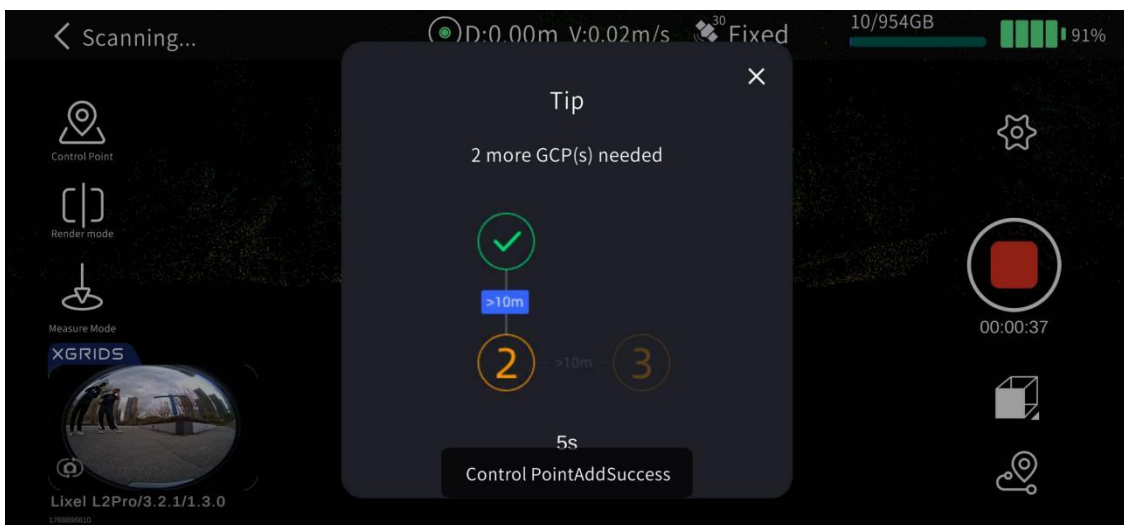

Pay attention to the names and order of the control points marked on the LixelGO when

tapping. When you do the processing in LixelStudio later, you need to ensure that the file names of the imported control points correspond to the names of the control points marked during the scan.

If the name of the added control point is repeated, the LixelGO will pop up a reminder, please judge and and modify it according to the specific situation.

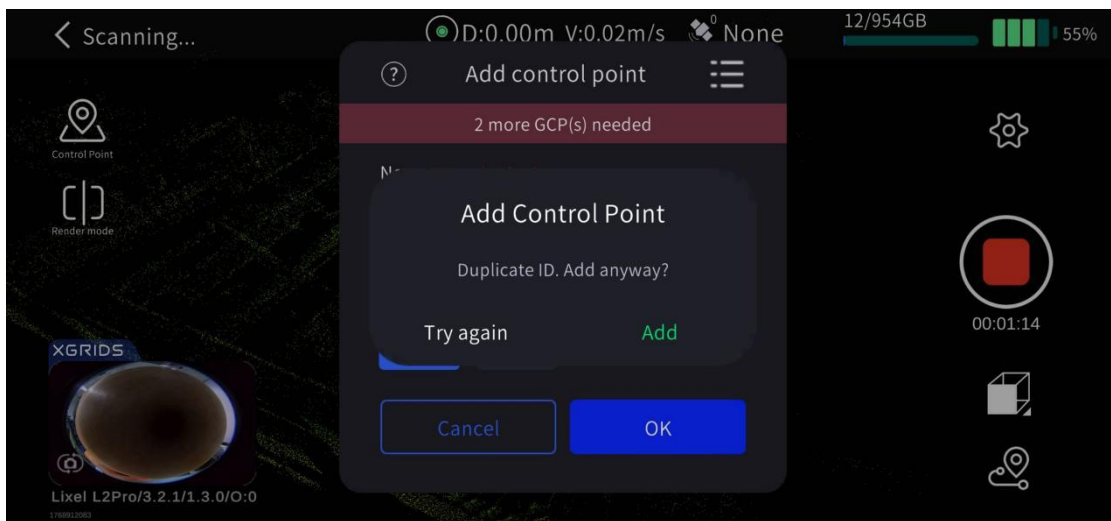
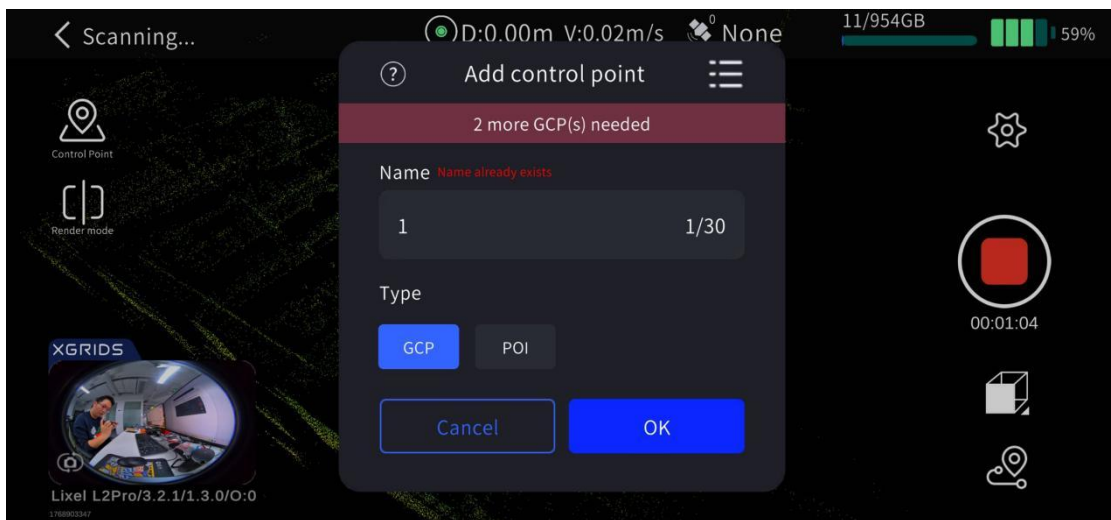

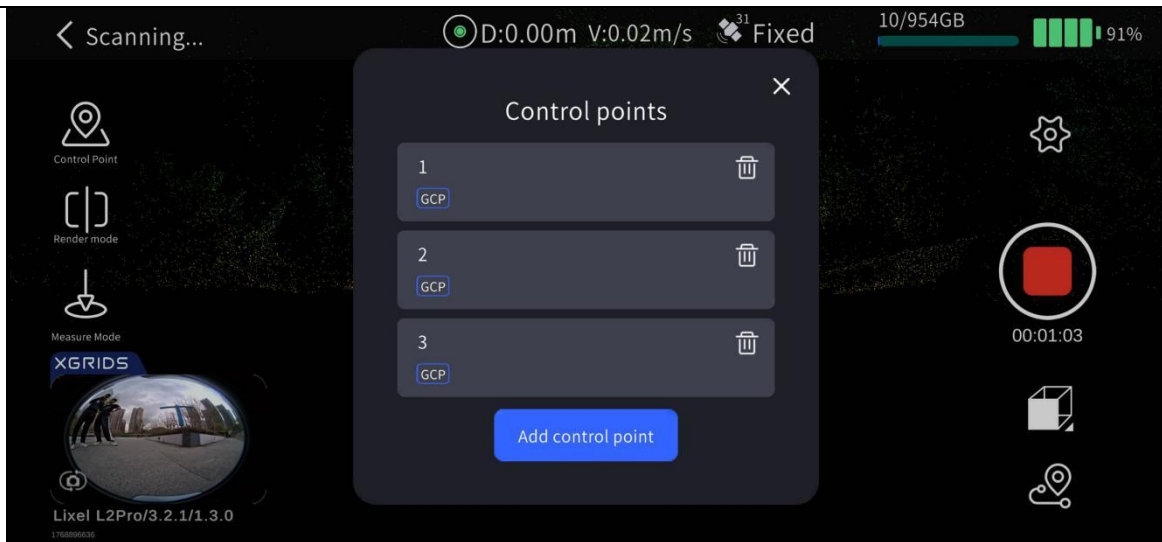

You can view the collected control points and delete control points in the "Control Point List" on the left side of the plane. Click the Delete button on the right side of the control point to delete the corresponding control point.

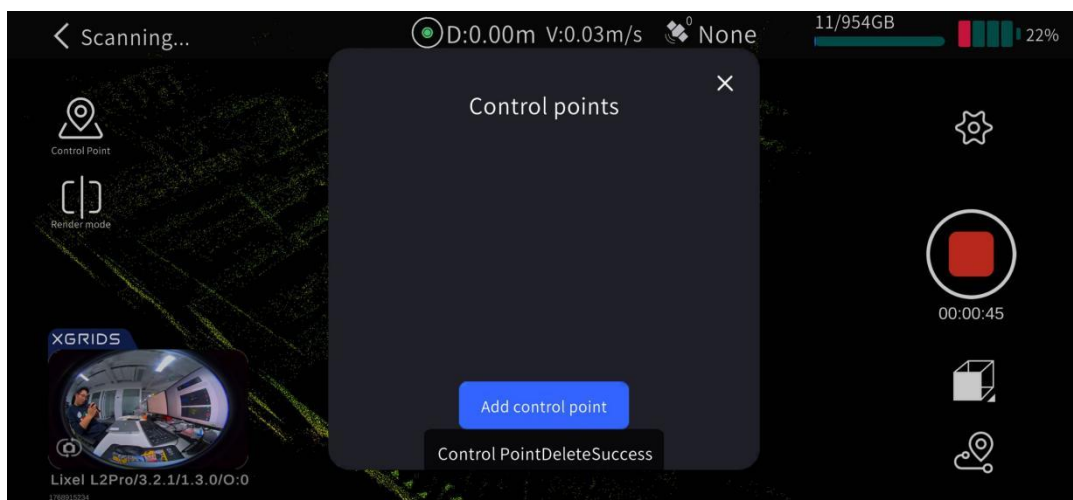
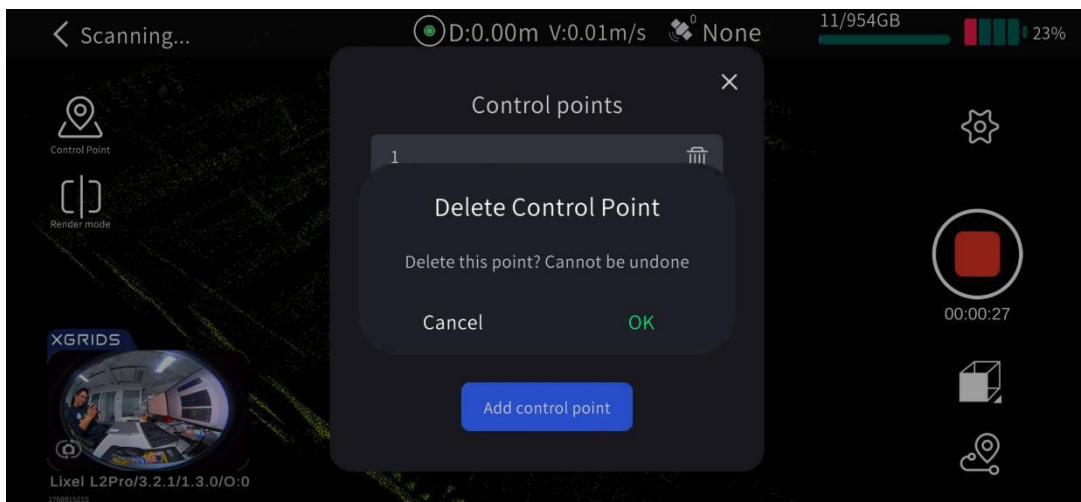

[POI] Click "+" on the left side of the screen to add POI.

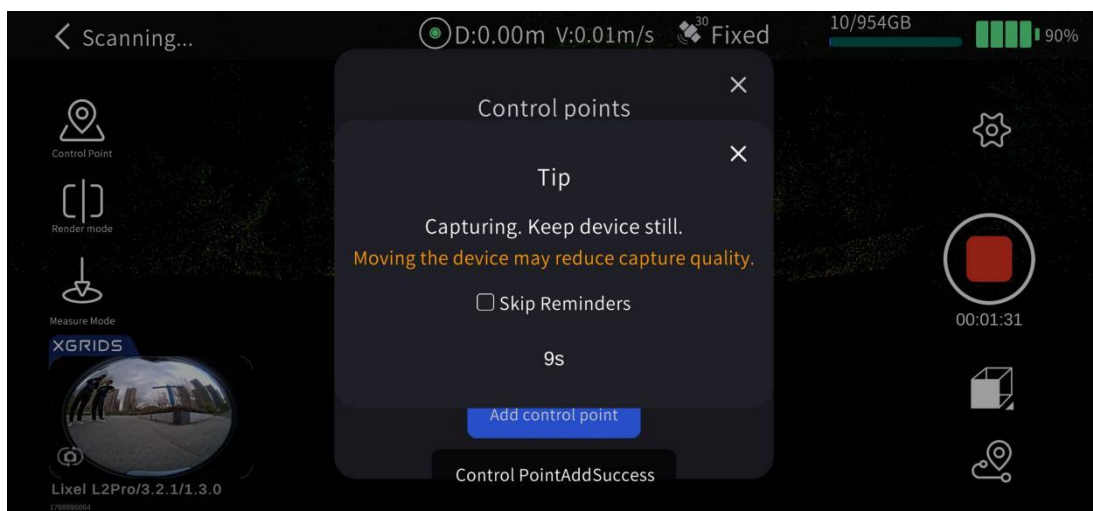
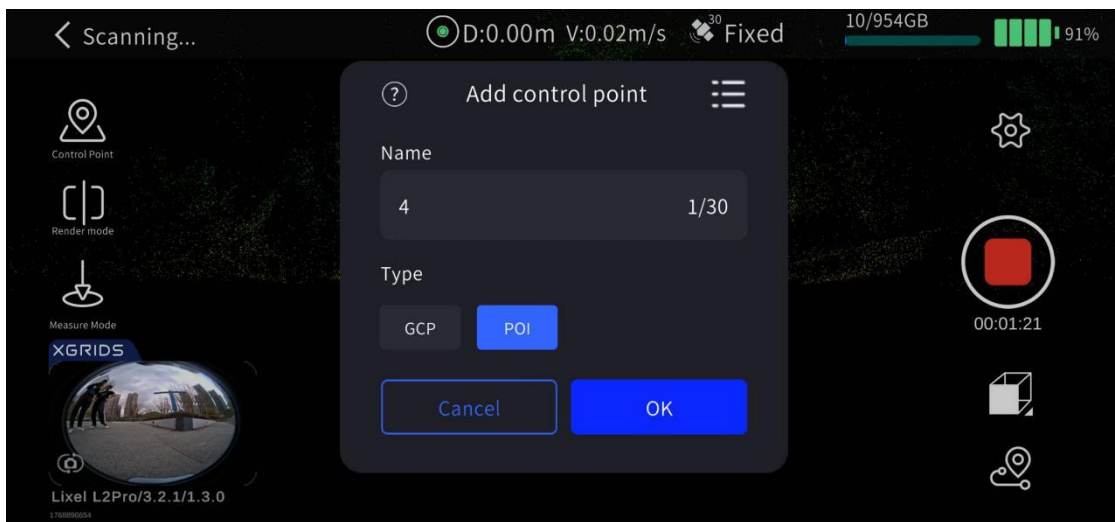

Stop scanning

Click the red End Recording button on the right side of the screen, the green light of the

device flashes, and the indicator light turns green and always on after scanning. Then you can shut down the scanner or start a second scan.

3. Office work: data processing

See the LixelStudio user manual for details.

5.2 Through the RTK module

With the RTK module, absolute coordinate information can be directly obtained during the scanning process, and the overall accuracy of point cloud data can be improved.

Note: In order to ensure good performance, please use this mode to scan when the outdoor RTK signal is good.

1. Scanner installation

The installation components include Lixel K2 Handheld Scanner, battery, base.

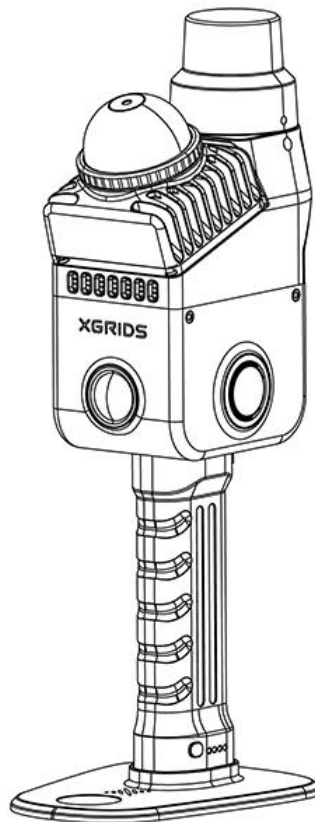

Note :

RTK module indicator lights have three statuses: red, blue and green.

Red: RTK not connected; Blue: RTK connected, not fixed; Green: RTK connected and has a fixed solution.

2. Field work: scanning

Scan route planning

According to the scanning environment, plan the scanning route reasonably, and ensure that the RTK signal is good during the scanning as much as possible. If you need to ensure the accuracy of point cloud after processing in LixelStudio, please ensure that RTK with no fixed solution does not exceed 50m during the scanning.

Connect the device

Turn on the scanner and connect the scanner through the LixelGO App. For specific steps, please refer to the Scanning Workflow.

RTK Account Settings

Enter the device windows, click RTK settings (satellite icon button), enter RTK settings. Currently there are 3 types of RTK configuration, custom, Qianxun SI, and China Mobile. Users can configure it according to the specific situation in different areas. Custom setting is as follows.

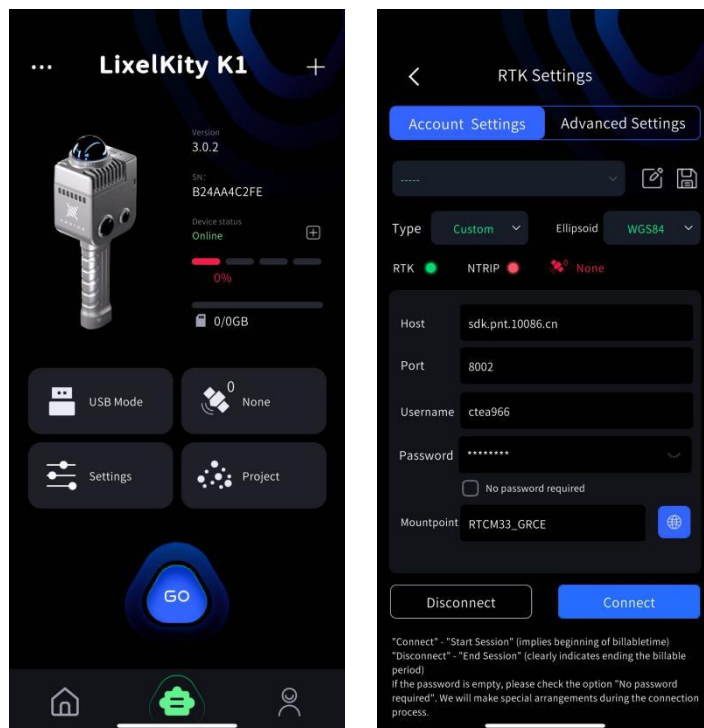

Account Management

When there are single or multiple frequently used accounts, RTK account information can be saved to the LixelGO app cache via the "Save" button.

Operation Steps

1. Enter RTK account information, including host, port, source node, etc.
2. Tap "Save", then select a configuration item to save in the pop-up window. The RTK account information will be saved to the LixelGO app cache.
3. Tap "Edit" to modify the configuration item name. After saving, the RTK account configuration name will be updated.
4. Saved configuration item information can be viewed in the drop-down menu.

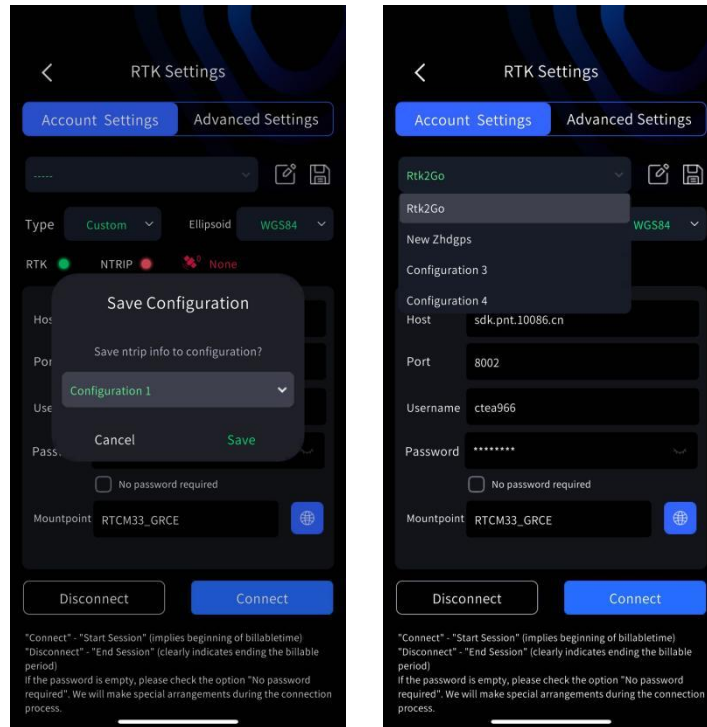

Attention :

1. Supported RTK: **Qianxun SI, China Mobile**, and standard-format custom RTK.
2. Auto-Login: Account setup is required only for first-time use; subsequent logins are automatic.
3. System Switch Delay: Changing coordinate systems requires a 5-minute sync time. Wait 5 minutes before proceeding.
4. Reference Systems: Supports WGS84, CGCS2000, and ITRF2008. Height is measured as geodetic height.

RTK Advanced Settings

GNSS Mode Settings

GNSS Mode Settings	Function Definition	Description
RTK	Real-time differential correction from the RTK module recorded in the project file.	On the startup page, select the RTK mode according to the project requirements. LixelStudio software requires an RTK module for project processing.
PPK	Post-processing correction using raw satellite data.	On the startup page, select the PPK mode according to the project requirements. LixelStudio software requires a PPK module for project processing.

Satellite System Setting

Customize satellite system selection with single, multiple, group selection, or select all options.

Requirements

Firmware version 2.3.0 or above.

The RTK module is connected to the scanner.

Satellite System Options

Device satellite system settings will be automatically read and displayed under Advanced Settings.

Select one or more satellite systems, or select all. Tap "Set" to apply immediately.



Start scanning

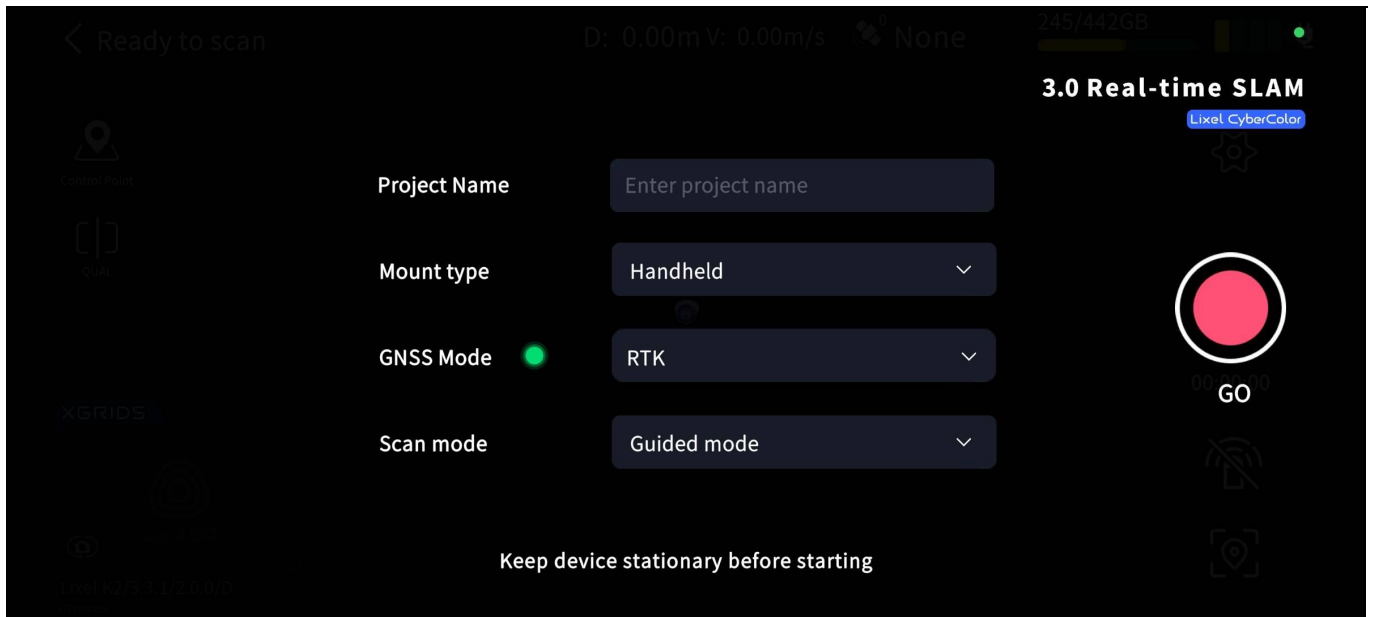

In RTK mode, wait for the RTK module indicator light to turn green, and the LixelGO displays that the RTK signal becomes Fixed before picking up the scanner and starting the scanning operation.

Attention :

1. RTK mode only supports scenes with RTK signals outdoors. RTK will not be able to obtain a fixed solution in indoor scenes.
2. During the RTK fixed solution, the RTK module indicator light turns green. If the light turns blue, pay attention to the satellite number.
3. Only if the satellite status on the LixelGO is fixed, you can start the scan. It can not be NONE, float, or single.
4. In order to ensure accuracy, it is recommended to make it sure that the device is in a fixed solution state most of the time during the scanning process. It is necessary to ensure that the RTK valid data is > 100 to achieve coordinate conversion successfully in LixelStudio.
5. When scanning, keep the scanner vertical and avoid tilting. When walking, the inclination angle of the scanner generally does not exceed 20° . In special cases, such as when scanning a small space or ground targets, the inclination angle of the device should not exceed 30° .

6. Pay attention to the scan space, and ensure that the scanning range is above 10m.

Stop scanning

Click the red End Recording button on the right side of the screen, the green light of the device flashes, and the device turns green and always on after scanning. Then you can shut down the scanner or start a second scan.

3.Data processing

See the LixelStudio instruction user manual for details.

6 Map Fusion

When there are effective control points and RTK data, multiple point clouds project can be seamlessly merged automatically. When there is absolute coordinate information, absolute coordinates can also be converted for point clouds. It can avoid overlapping area layering caused by RTK or control point accuracy problems when using global optimization alone.

6.1 Field work: scanning

Refer to "5 Acquire point cloud data with absolute coordinates" for specific operation.

Fusion Guidelines:

1. Overlap Length: Maintain a path overlap of 15–30m between adjacent maps.
2. Environment: Choose overlap areas with rich structural features. Avoid "degraded" environments like tunnels, corridors, or empty fields.
3. Control Point Consistency: For overlapping projects, ensure the same control points use identical names and positions. A minimum of 15m scan overlap is mandatory.
4. Transformation Minimums: * Maps must be linked by control points.
 1. Minimum of 3 referenced ground control points total.
 2. Points must be distributed (not in a single straight line).

5. Note: Data fusion will fail if the above conditions are not met.

6.2 In-house: data processing

See the LixelStudio user manual for details.

7 Route planning suggestions for typical scenes

7.1 Principles of the overall scanning route

1. Ensure as many features as possible during the scanning process.
2. Avoid scanning new areas all the time, and making some loops as much as possible.
3. Avoid the impact of dynamic objects as much as possible.

7.2 Outdoor scenes

Typical scenarios: parks, campuses, buildings, etc



Not recommended route



Recommended route

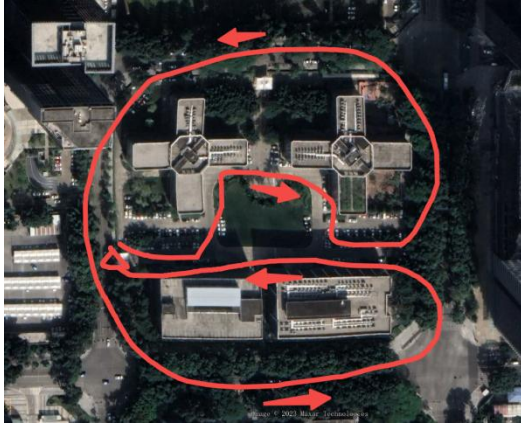

Not recommended route



Recommended route

Feature-rich scenes: (texture and text-heavy):

Aim the front camera toward the scan area and sweep in a vertical "U" motion.

Recommended scanning speed: ≤ 1.0 m/s for general scenes; ≤ 0.5 m/s for high-detail capture

Maintain a distance of roughly 0.8–1 m from the subject

Ground markers: Tilt the device downward (no more than 30°) for high-detail capture.

7.3 Indoor scenes

Taking common office as an example

1. Route planning

1. Such as indoor parking lots those are more than one floor, it is recommended to scan from top to bottom and snake around.

2. The control point recording method is consistent with the parking lot scene, and the absolute coordinate control point is selected to record with the core area.

2. In and out

Error example: Entering through the door from the front will make the indoor and

outdoor laser point cloud data lose the common FOV, lose the reference, and cause the data to be skewed.

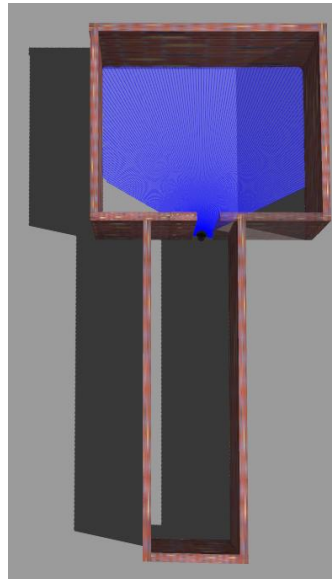
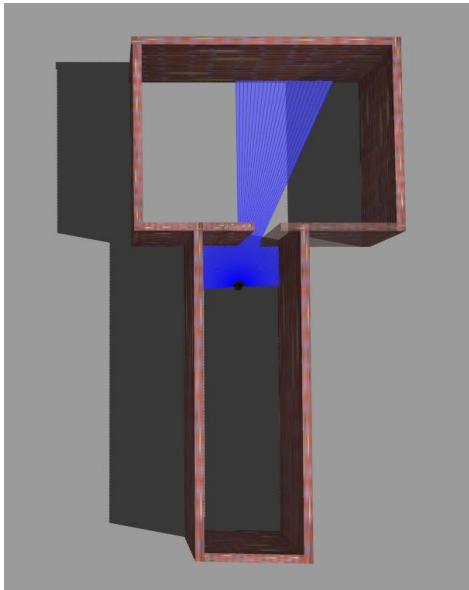

The correct example is to get through the door sideways to ensure that the indoor laser point cloud and the scanning field before entering the door have a common FOV, better connection, indoor and outdoor data.

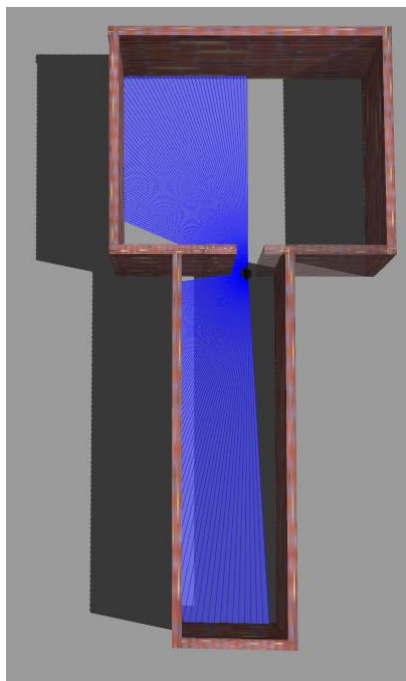
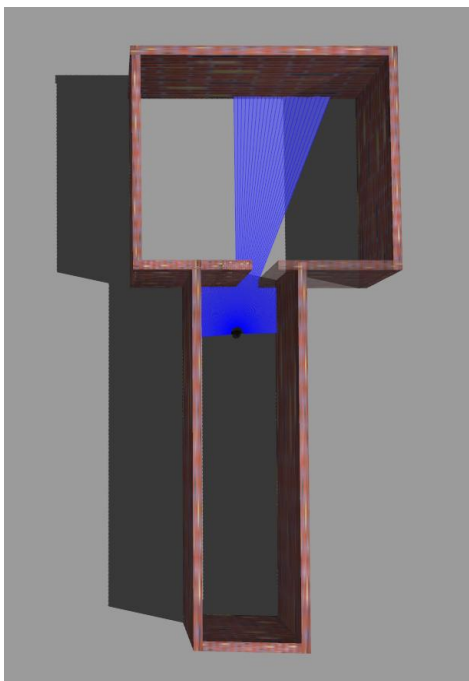

3. Hanging corner

Error example: Go straight ahead resulting in the loss of the wall view in the lower left

corner. And the laser point cloud lacks a reference and is prone to misalignment.

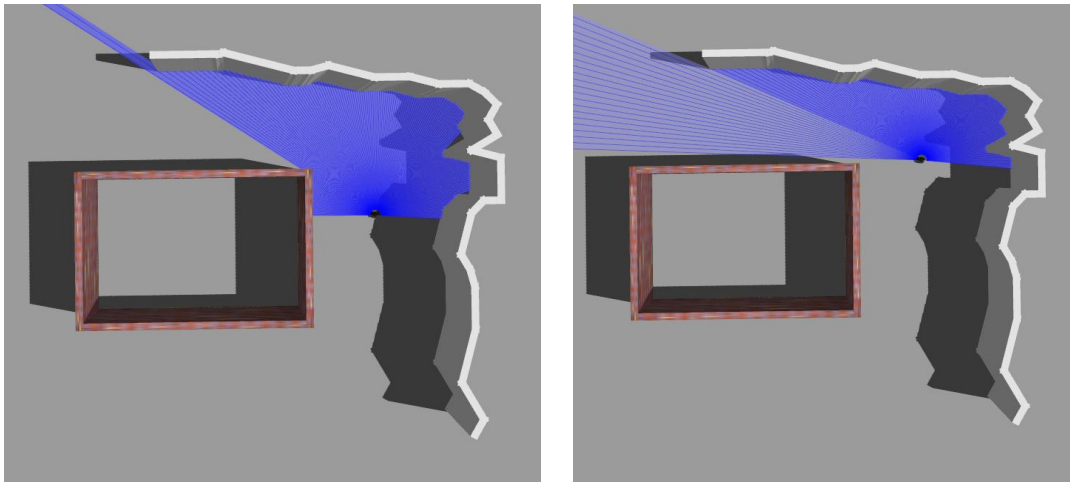

Correct example: When turning, turn sideways at a certain angle to ensure that the laser can scan the lower left corner wall and the right side contour at the same time, which can better connect the data.

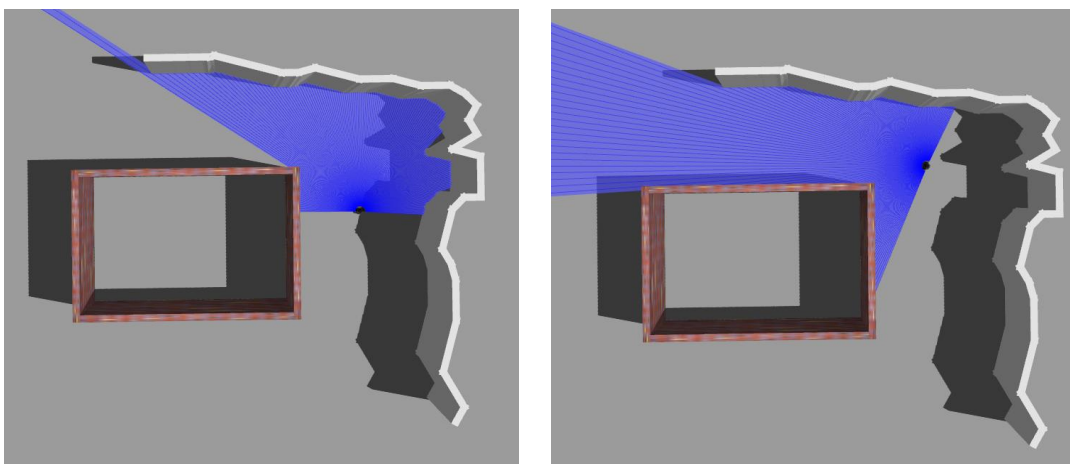

4. In and out of confined spaces

After scanning a small space and exiting from the space, it is necessary to observe whether the reference objects are sufficient and whether the structural features are obvious during the scanning process. If the above two conditions are not met, when exiting, try to align the perspective with areas with good structural features as much as possible, while avoiding excessive perspective switching.

Error example: Directly turning around and exiting. This will result in missing reference objects and insufficient structural feature constraints of reference objects.

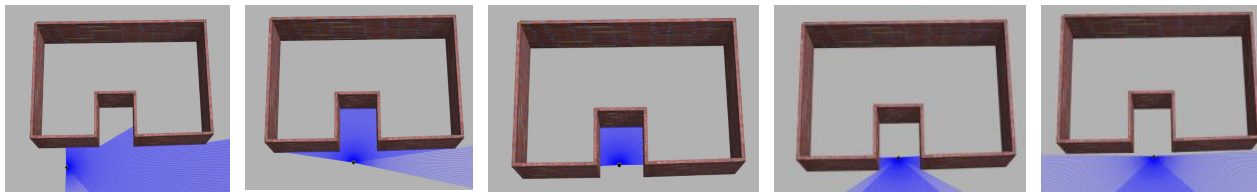

Correct example: exit by moving back or exiting sideways

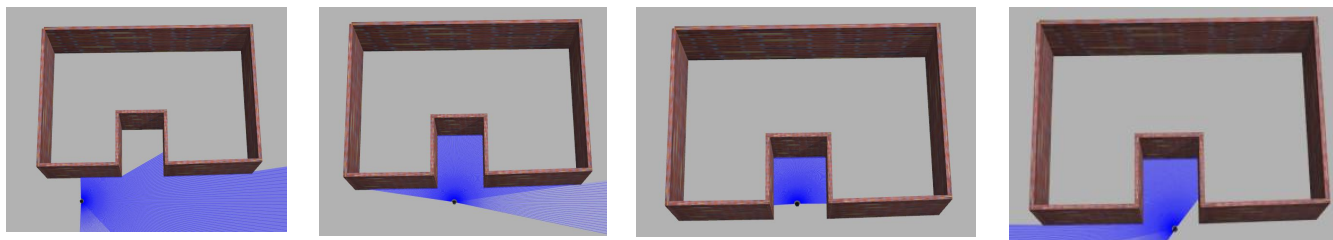

5. Ceilings and Floors

In narrow spaces, the LiDAR FOV may require a moderate device tilt ($<30^\circ$). Where coverage is still insufficient, supplement by slowly tilting the device more steeply ($>30^\circ$, $<60^\circ$) in a relatively static scene for no more than 30 seconds to capture the floor or ceiling.

8 Precautions

8.1 Startup (Instrument Initializing)

1. Place the device on a flat surface. Keep it still — no shaking, no people or objects in front of the LiDAR.
2. Wait at least 10 seconds for the point cloud to appear in LixelGO. Follow the app prompts until initialization completes.
3. Pick up the device slowly. Avoid sudden movements.
4. Aim the LiDAR at feature-rich surroundings during initialization. Avoid open areas, large glass surfaces, and scenes with heavy foot or vehicle traffic. Stand slightly back from the device so you do not block the LiDAR.

8.2 General notes

1. Walk at a steady, normal pace. Slow down in narrow spaces, around corners, and in feature-sparse areas. Avoid sudden stops or sharp body movements.
2. Keep device tilt under 15° during normal walking. Tilt may briefly reach 30° when capturing floor targets or tight ground detail.
3. Keep the LiDAR field of view clear. Do not let any object cover more than 50% of the FOV or sit within 1 m for extended periods.
4. Maintain at least **0.5 m** from the subject being scanned.
5. For critical ground detail, scan closer and hold the device at chest height — do not lower it toward the floor.
6. In traffic-heavy outdoor scenes, aim the LiDAR away from the side with the most moving vehicles or pedestrians.
7. Doorways (multi-room or multi-floor scans):
 - Open doors before you reach them.
 - Pass through slowly, pausing sideways in the doorway so the LiDAR sees both rooms at once.
 - If you must open a door during scanning, turn your back to the door, open it behind you, and walk in backward.

8.3 Ground Control Mode

1. Place and lift the scanner gently at each control point. Impact or sudden movement reduces accuracy.
2. Wait for LixelGO to confirm the control point is added, then walk a full loop (or two) around the point to capture complete surrounding coverage.
3. Wait at least 15 seconds after marking the final control point before ending the

project.

4. Keep GCPs within 50 m of each other, distributed evenly across the scan area. GCPs must not fall on a single straight line.

8.4 RTK mode

1. RTK mode requires an outdoor differential signal. It will not work indoors.
2. Tilt limits (angled RTK bracket):
 1. Device body: up to 20° from vertical
 2. RTK antenna: up to 10° from vertical These are independent limits — both must be respected.
3. Scan an area at least 10 m wide. Coordinate conversion in LixelStudio requires a minimum of 20 valid RTK points; below that, conversion will fail. For reliable accuracy, aim for >100 valid RTK points and keep stretches of unfixed solution under 50 m.
4. For accuracy checks, the capture route must be longer than 100 m and must not be a straight line.
5. To ensure the accuracy of point cloud post-processing, it is recommended to ensure RTK does not stay in an “unfixed” solution for over 50m.

8.5 Colorization mode

1. Scan for at least 2 minutes and keep moving throughout. The scanner must not remain stationary.
2. Colorization quality depends on ambient light. Add even, diffused lighting in dark environments. Avoid overexposure and harsh direct light.
3. Do not block the panoramic camera or the built-in cameras. Keep both sides of the device clear of hands and objects while scanning.

8.6 Accuracy Check

For accuracy check, the points where the target is pasted need to be scanned around the target or stay at the target appropriately to obtain a more complete target point cloud so as to improve the success rate of automatic target point extraction in subsequent accuracy check in LixelStudio.